

Temporary demountable structures



Guidance on procurement, design and use

Third edition







April 2007

Temporary demountable structures

Guidance on procurement, design and use

Third edition

Acknowledgements

The first edition of this *Guide* was prepared in association with the Steel Construction Institute whose contribution is gratefully acknowledged.

The second edition of this *Guide* was prepared with support provided by the Implementation Monitoring Group and the Department of the Environment, Transport and the Regions.

Unless stated otherwise below, all the figures in this *Guide* have either been especially commissioned for this third edition or are provided courtesy of the members of AGOTS or their employers (see list of AGOTS members opposite). Figures from other sources are courtesy of the following:

- 3A Entertainment Ltd (front cover, upper).
- Baconinflate Ltd and AKSWard (front cover, lower).
- Live Nation (Music) UK (Figure 3).
- Building Research Establishment Ltd (Figure 12).
- Total Fabrications Ltd and AKSWard (Figures 23 and 29, right).
- Eve Trakway (Figure 31).
- MOJO Barriers BV (Figures 36 and 37).

Copyright in the relevant Figures is retained by the above, the members of AGOTS or their employees who provided them, as appropriate.

CONSTITUTION OF TASK GROUP

This *Guide* was prepared by the Institution of Structural Engineers in association with the Advisory Group on Temporary Structures (AGOTS). The members of the group and the organisations they represented are listed below:

Chairman	R. Barrett Star Events Group Ltd
Vice Chairman	P.M. Hind BSc(Eng), CEng, MICE, FIStructE AKSWard Ltd
Core Cities Group	S. Willett BSc, CEng, MICE, MRICS Glasgow City Council
Communities and Local Government	R. Shipman BSc, CEng, MICE, PGCE
The Event Services Association	J. O'Neill Arena Seating Ltd
The Institution of Civil Engineers	J. P. Cowan BSc(Eng), CEng, FICE, FCIWEM, FCIBSE, FEWI Geoffrey Hunt & Partners
The Institution of Structural Engineers	J. P. Blakeman BSc, CEng, FIStructE, FConsE Clarke, Nicholls & Marcel J.G.H. Cullack BSc(Eng), ACGI, CEng, MIStructE, MCS NRM Bobrowski Dr J. F. Dickie PhD, BSc, CEng, MIStructE Crowdsafe Ltd Dr A. J. M. Soane PhD, BSc(Eng), CEng, FIStructE, FICE CROSS – Confidential Reporting on Structural Safety
The Performance Textiles Association	A. Dann Danco plc
The Production Services Association	S. James HND Eng Tech IOSH Event Safety Shop Ltd
By invitation	M. Blackburn Grandstands Worldwide S. W. Brackley Hussey Seatway Ltd M. Bunting N.H. Darracott MEng, CEng, MIMechE Xolve Ltd
Technical editor	P.M. Hind BSc(Eng), CEng, MICE, FIStructE AKSWard Ltd
Secretary	Dr J.D. Littler PhD The Institution of Structural Engineers

Published by [The Institution of Structural Engineers](#), International HQ, 11 Upper Belgrave Street, London SW1X 8BH

First published 1995

Second edition published 1999

Third edition published 2007

ISBN 978-0-901297-45-7

© 2007 The Institution of Structural Engineers

Front cover: Large outdoor concert showing typical stage structure and seating areas, Bath, UK (top)

Custom built concert stage and scenic elements, Milton Keynes, UK (bottom).

Inside front cover: Audience area tower structures to support lighting, sound and video equipment.

The Institution of Structural Engineers and the members who served on the Committee which produced this *Guide* have endeavoured to ensure the accuracy of its contents. However, the guidance and recommendations given in the *Guide* should always be reviewed by those using it in the light of the facts of their particular case and specialist advice obtained as necessary. No liability for negligence or otherwise in relation to this *Guide* and its contents is accepted by the Institution, the members of the Committee, their servants or agents. **Any person using this Guidance should pay particular attention to the provisions of this Condition.**

No part of this publication may be reproduced, stored in a retrieval system or transmitted in any form or by any means without prior permission of the Institution of Structural Engineers, who may be contacted at 11 Upper Belgrave Street, London SW1X 8BH.

CONTENTS

FOREWORD	ix
GLOSSARY	xi
1 INTRODUCTION AND SCOPE	2
1.1 Introduction	2
1.2 Scope and purpose of the <i>Guide</i>	2
1.3 Status of the <i>Guide</i>	3
2 PRINCIPAL RESPONSIBILITIES	6
2.1 General	6
2.2 Responsibilities of clients, venue owners and event organisers	6
2.3 Responsibilities of designers and contractors	7
2.4 References	7
3 HAZARDS AND RISKS RELATING TO DEMOUNTABLE STRUCTURES	10
3.1 Hazards	10
3.1.1 Design hazards	10
3.1.2 Erection and dismantling hazards	10
3.1.3 Operational hazards	10
3.2 Risk assessment	10
3.3 Steps to minimise risks	11
3.3.1 Design	11
3.3.2 Erection and dismantling	11
3.3.3 Operation	12
3.4 Crowd behaviour	12
3.4.1 Introduction	12
3.4.2 Crowds	13
3.4.3 Crowd control or crowd management	14
3.5 Fire	15
3.6 Safety planning	16
3.6.1 Introduction	16
3.6.2 The safety plan	16
3.7 References	16
4 STATUTORY CONTROL	20
4.1 General	20
4.2 Building Regulations	20
4.2.1 England and Wales	20
4.2.2 Scotland	20
4.2.3 Northern Ireland	20
4.3 Planning permission	21
4.4 Premises licensed for public entertainment (not including sports grounds)	21
4.4.1 England and Wales	21
4.4.2 Scotland	21
4.4.3 Northern Ireland	22
4.5 Sports grounds	22
4.5.1 Sports grounds safety certification	22
4.5.2 Sports grounds prohibition notices	24
4.6 Public Health Acts Amendment Act 1890	24
4.7 Local acts in England and Wales	24

4.8	Fire precautions	25
4.9	Health and Safety at Work etc. Act 1974	25
4.10	References	25
5	PROCUREMENT AND USE	28
5.1	Procurement	28
5.1.1	General	28
5.1.2	Specification of requirements	28
5.1.3	Compliance with regulations	29
5.1.4	Design and checking	29
5.1.5	Equipment checking	29
5.2	Documents	30
5.2.1	Safety policies	30
5.2.2	Risk assessments and safety plans	30
5.2.3	Method statements	30
5.2.4	Major incident plans	30
5.2.5	Fire certificates	30
5.2.6	Independent erection check and completion certificate	30
5.2.7	Document check list	30
5.3	Use	32
5.3.1	Supervision during the event	32
5.3.2	Access and egress	32
5.3.3	Electrical installations and lightning protection	32
5.3.4	Fire safety	32
5.3.5	In-service inspection and maintenance	32
5.4	References	33
6	GROUND AND SITE CONDITIONS	36
6.1	Introduction	36
6.2	Information	36
6.3	Basic principles	36
6.4	Ground bearing pressures	37
6.5	Foundations	37
6.6	Soleplates, baseplates and spreaders	38
6.7	Ground anchors	39
6.8	Sloping ground	39
6.9	Site drainage	40
6.10	Inspection	40
6.11	References	40
7	ERECTION, INSPECTION AND DISMANTLING	42
7.1	Erection	42
7.1.1	Planning	42
7.1.2	Work on site	42
7.1.3	Erection check	44
7.2	Dismantling	45
7.3	Inspection of components	45
7.3.1	Repeated use of components	45
7.3.2	Scaffolding components	46
7.3.3	Inspection of structural components used repetitively	46
7.4	References	48

8	WIND LOADING	50
8.1	Introduction	50
8.1.1	General	50
8.1.2	Basic principles	50
8.1.3	Design principles	52
8.2	Wind loading on structures	53
8.2.1	Grandstands	54
8.2.2	Stages	54
8.2.3	Special Structures	54
8.2.4	Operations management for wind Option (b)	55
8.3	Wind loading on tents and marquees	56
8.3.1	Basis	56
8.3.2	PTA Method	56
8.4	References	58
9	GRANDSTANDS	60
9.1	Introduction	60
9.2	Materials	60
9.3	Design principles	60
9.4	Design guidance	62
9.4.1	General	62
9.4.2	Loading	62
9.5	Connections	65
9.6	Loading tests	65
9.7	Layout criteria (means of escape)	66
9.8	Barriers and handrails	66
9.8.1	General	66
9.8.2	Protection against falling	66
9.8.3	Design of barriers	67
9.9	Demountable standing accommodation	67
9.10	Viewing facilities for wheelchair users	68
9.10.1	General	68
9.10.2	General principles	68
9.10.3	Design requirements – platforms	69
9.10.4	Design requirements – access ramps	69
9.10.5	Seating arrangements and capacities	70
9.11	References	72
10	STAGES AND SIMILAR STRUCTURES	74
10.1	Introduction	74
10.2	General design requirements	74
10.2.1	Introduction	74
10.2.2	Calculations	74
10.3	Stage types	75
10.3.1	Stage floor platforms and associated sub-structures	75
10.3.2	Roofs	76
10.3.3	Free standing roof systems	77
10.3.4	Roof systems that are supported on a stage floor	77
10.3.5	Roof systems supported within the sub-structure of a stage floor	77
10.3.6	Fully integrated units that are typically vehicle based	78
10.4	Access and egress for non-public use	78
10.5	Protection against falling	79
10.6	Use of lifting equipment in the construction and use of stages	80
10.7	References	80

11	BARRIERS FOR EVENTS	82
11.1	Introduction	82
11.2	Design	85
11.2.1	Design loading	86
11.3	Hoarding or fences outwith the main viewing areas	87
11.4	Site conditions/barrier performance	87
11.5	Multiple barrier arrangements	88
11.6	Event risk assessment	89
11.7	Installation and inspection	89
11.8	References	89
12	TENTS AND MARQUEES	92
12.1	Introduction	92
12.2	Design	93
12.2.1	General	93
12.2.2	Anchors	93
12.2.3	Wind loading	94
12.2.4	Flame retardancy of fabric and materials	94
12.3	Procurement and use of tents and marquees	95
12.3.1	Safety considerations – client	95
12.3.2	Safety considerations – contractor	96
12.4	Erection, inspection and dismantling of tents and marquees	96
12.4.1	Erection	96
12.4.2	Inspection	96
12.4.3	Dismantling	97
12.5	Verification	97
12.6	References	98
13	ANCILLARY AND SPECIAL STRUCTURES	100
13.1	Introduction	100
13.2	Design	100
13.2.1	General considerations	100
13.2.2	Verticality	101
13.2.3	Stability	101
13.2.4	Overloading	101
13.2.6	Scaffold	102
13.2.7	Access	102
13.3	Masts and towers	102
13.4	Catenary wire ropes	103
13.5	Hospitality units	104
13.6	References	104
	APPENDIX	
	SOURCES OF INFORMATION	105

FOREWORD

Two serious incidents of instability of spectator seating occurred in the UK during 1993 and 1994: 18 people were injured in April 1993 when seating collapsed at a gospel meeting, and about 1100 spectators were involved in the collapse of a demountable structure at a pop concert in October 1994.

The urgent requirement to provide guidance was recognised and supported financially by the Department of the Environment. As a result the Institution of Structural Engineers, in collaboration with the Steel Construction Institute, published the first edition of this *Guide* in October 1995. Although this *Guide* fulfilled its immediate purpose, subsequent debate revealed the need for a greater contribution by industry covering a wider range of temporary structures. The constitution of the committee responsible for the development of the second edition was extended to include trade associations because of their knowledge and experience of demountable structures. An Implementation Monitoring Group was formed with representatives of government, industry, and the Institutions of Structural and of Civil Engineers.

Following publication of the second edition in 1999, the Implementation Monitoring Group was re-named as the Advisory Group On Temporary Structures (AGOTS). Since then, the industry has seen several technological and regulatory changes. Regrettably there have been a number of structural failures at events in recent years which has led to calls for updated guidance, especially with respect to the actions of wind on temporary structures.

The third edition of this *Guide* builds on information provided in the second edition and is intended for clients and for local authorities, contractors and suppliers of demountable structures for events. It is also an advisory document for use by competent persons who are responsible for the design of demountable structures.

The spirit of cooperation and dedication displayed by the members of AGOTS is gratefully acknowledged. I would also like to thank the many other contributors who freely gave of their knowledge and experience to assist the development of this guidance.

I am indebted to Dr John Littler, Secretary to the Group. The task of efficient administration and maintaining the effort to achieve the tight programme of assessment, review and publication has made heavy demands on his busy institutional workload.

I am also grateful to HSE for their endorsement of the third edition below.



Roger Barrett
Chairman, AGOTS
February 2007

The HSE welcomes this third edition of *Temporary demountable structures – Guidance on procurement, design and use* and considers it an important document in supporting the effective management of health and safety risk with regard to these structures. The direct involvement of experienced and professional practitioners ensures that such guidance will be both relevant and authoritative.

GLOSSARY

The definition of the following terms as used within this *Guide* is set out below. No attempt has been made to define all the terms in this *Guide* that might be unfamiliar to the general reader, but which have widespread use within the entertainment sector.

Chartered engineer Chartered structural or civil engineer, being a member of the Institution of Structural Engineers or the Institution of Civil Engineers, with appropriate experience in the context of this *Guide*.

Client Person or organisation who procures a demountable structure for use at an event; this may be the owner of the venue, site or building where an event takes place but is not necessarily the event organiser.

Competent persons People shall be regarded as competent where they have sufficient training and experience to take responsibility for an identified task. It is important that they have a detailed knowledge of the type of structure, and particularly of those matters which are essential for its structural reliability. Competent persons will have an awareness of the limitations of their own experience and knowledge. A competent person is required to confirm that a structure has been erected in accordance with the actual design.

Completion certificate A certificate or written record prepared by a contractor to confirm that the appropriate independent erection checks have been carried out and that a temporary structure has been erected in accordance with the design drawings and documentation.

Contractor A firm which is contracted, by the client, to supply and erect a structure.

Design check See 'Independent design check'.

Design documentation Documents provided by the designer of a temporary structure that enable the basis of design to be clearly understood and the design criteria to be verified. They should include drawings, calculations, certificates, statements of loading, risk assessments, method statements, etc.

Design wind speed Maximum wind speed that a temporary structure is designed to withstand.

Designer All structures should be properly designed by a competent person. The designer should be able to offer evidence of their competence. Evidence of the design process being carried out should be available. Where structures are intended for repetitive use, a standard design is acceptable provided that evidence of the original design is available.

Engineering documentation These documents shall include the structural calculations, drawings and specifications, risk assessments and method statements.

Enforcing Authority The organisation which controls the issue of approvals. This may be the Local Authority.

Event A public or private occasion at which spectators are present.

Event organiser An individual or organisation that promotes and manages an event. This may not always be the client.

Independent design check (1) A check of a standard system, which may be based on design or have evolved on an empirical basis, by a chartered engineer having appropriate skill and experience. (2) A check of the design of any special or non-standard arrangement of elements supplied for a project, carried out by a chartered engineer having appropriate skill and experience of such design.

Independent erection check An inspection of a temporary structure by a competent person made after every erection of the structure. The competent person may be an employee of the supplier of the structure or a person nominated to carry out such inspection by the supplier. Where the erection check is carried out by a member of the erection team, evidence of that person's competence should be made available. The results of this inspection should be recorded on a form (the completion certificate) designed for this purpose by the contractor.

Kentledge Dead weight, normally steel or concrete but could include containers filled with water or granular material. The term ballast is sometimes interchangeable with kentledge.

Local authority The organisation which controls the issue of Building Regulations approvals, safety certificates and licences under relevant legislation. The local authority is also the responsible body for planning permission (but not in Northern Ireland).

Marshal An alternative word for steward at sports events. However, a marshal may have a specific role at some events, e.g. racecourses, motor sports.

Operational wind speed Maximum wind speed at which a temporary structure is designed to be used.

Owner The owner of the venue, site or building where an event takes place.

Risk assessment The process by which a competent person identifies the hazards associated with the design, construction or operation of a temporary demountable structure, determines the level of risk for people constructing or using the structure, and assesses the likelihood and consequences of an incident.

Safety coordinator Person responsible for implementing a safety plan – a representative of the owner or the event organiser. At sporting events covered by a safety certificate, the safety coordinator will be the safety officer.

Safety plan A document which identifies the hazards and associated risks relating to the design, procurement, construction and use of the temporary demountable structure for the proposed event, and sets out responsibilities for managing the risks. Safety plans should be subject to continual review and periodic formal revision.

Stage A structure that comprises a performance area with roof cover and associated side and rear walls (where applicable).

Steward A competent person employed for major events by the client and whose duties are as defined in Section 3 of the *Guide to Safety at Sports Grounds*. At certain sporting events, a steward is referred to as a marshal.

Structural Safety Structural safety refers to the strength, stability and integrity of a structure to withstand the conditions that are likely to be encountered during its life-time. Structural safety is achieved through the proper procurement, design, construction, use and maintenance of the structure and the application of best practice.

Supplier See ‘Contractor’.

Temporary demountable structures Structures which are in place for a short time, generally no more than 28 days, that are designed to be erected and dismantled manually many times. They are usually made from lightweight components and are used for a wide variety of functions at public and private events. They include grandstands, tents and marquees which may accommodate large numbers of people, and stages and supports for performers.

SECTION 1 INTRODUCTION AND SCOPE

This Section is intended for all readers

“This *Guide* is concerned with the structural safety and adequacy of demountable structures used for temporary purposes and also with the overall planning and management of events.”

“Demountable structures are widely used for a variety of functions at public and private events. They may provide viewing facilities (including temporary seating), shelter (tents and marquees), platforms and supports for performers (such as stages), and for media facilities (such as supports for floodlights, loudspeakers, TV cameras, vision screens and press boxes).”

“Demountable structures are often required at short notice. Timescales frequently make it necessary for clients, contractors and local authority officers to make decisions relatively quickly.”

“The achievement of safety requires judgment based on experience and careful evaluation of relevant factors. Each case should be judged on its individual circumstances. It is not merely a matter of the rigid application of standards.”

“The approach to risk management should always be one of flexibility and sound judgment. Unjustifiably onerous or inappropriate requirements do not contribute to public safety and in some unfortunate instances may create risks in themselves. An objective assessment by a competent person is required.”

1 INTRODUCTION AND SCOPE

1.1 Introduction

Demountable structures are widely used for a variety of functions at public and private events. They may provide viewing facilities (including temporary seating), shelter (tents and marquees), platforms and supports for performers (such as stages), and for media facilities (such as supports for floodlights, loudspeakers, TV cameras, vision screens and press boxes). They can be found at exhibitions, sporting events, musical concerts and social occasions. Some may carry substantial numbers of people during major events.

Key factors relating to temporary demountable structures include the following:

- Demountable structures are often required at short notice.
- Timescales for planning, installing and erecting temporary structures before the event and removing them afterwards frequently make it necessary for clients, contractors and local authority officers to make decisions relatively quickly.
- Temporary structures may need to withstand substantial horizontal, vertical and dynamic loadings from crowds, and from wind.
- The structural components are often required to be lightweight, rapidly assembled, readily dismantled and reusable.

Requirements for a demountable structure can be specified by the owner of the venue where an event is to take place or, more usually, by the organiser of the event. Whoever instructs the contractor becomes 'the client' and, as such, should provide a clear written specification to the contractor.

The fact that a structure is designed for temporary use does not change the overall requirements for safety; the failure of any temporary structure in a crowded, confined space could have devastating effects. Although the time available from concept to use for an event may be limited, it is essential to design structures to suit the specific intended purpose and to recognise that the key to the safety of temporary demountable structures lies largely in the proper planning and control of work practices coupled with careful inspection of the finished structure.

Temporary demountable structures are usually designed to be easily erected and dismantled, and are capable of adaptation to different situations. This often means that they are relatively lightweight

structures made from slender components and need to be designed, erected and inspected before use by competent persons.

Both the venue owner and the event organiser have responsibilities for the safety of people attending the event, but everybody involved in planning, design, erection and management of a temporary demountable structure owes a duty of care in relation to the safety of the structure and to people working on and using the structure.

Contact with local authority officers, fire officers and police may be necessary to obtain approvals relating to the adequacy of the structure, fire precautions, seating, layout, and entry and exit arrangements.

The achievement of safety requires judgment based on experience and careful evaluation of relevant factors. Each case should be judged on its individual circumstances. It is not merely a matter of the rigid application of standards.

In recent years the traditional structural engineering response to public assembly safety has broadened to include environmental psychology, fire engineering, information systems and management systems. The outcome can be simply expressed as the emergence of the concept of 'crowd management' as opposed to 'crowd control'. Emphasis is placed on public safety as opposed to public order, recognising the need for planned rather than reactive crowd management.

The approach to risk management should always be one of flexibility and sound judgment. Unjustifiably onerous or inappropriate requirements do not contribute to public safety and in some unfortunate instances may create risks in themselves. An objective assessment by a competent person is required.

This *Guide* is based on practice in the United Kingdom but the principles described may be appropriate for application elsewhere.

1.2 Scope and purpose of the Guide

Demountable structures considered in this *Guide* include free-standing demountable temporary grandstands, platforms, stage structures and barriers. Temporary structures such as towers and masts to support media facilities, and canopies, tents and marquees are also included. Where a demountable structure is to be used at a sports ground or designated football stadium, local authorities may attach special conditions to certificates controlling its use.

Retractable seating and fairground structures are not considered in this *Guide*.

The purpose of this *Guide* is to give the designer

information to assist in achieving the safe and economic design of temporary demountable structures and to encourage their safe and economic erection. It is hoped that this design process will be generally recognised and applied uniformly across the country.

To fulfil this aim, this *Guide* provides information to assist the designer to evaluate the loads likely to be imposed on the temporary demountable structures. In some cases an engineering appraisal will be required of the recommended levels of loading to adjust these to the particular circumstances, such as the planned activity or possible misuse.

The *Guide* is also intended for clients, event organisers and venue owners, regulatory and local authorities, as well as contractors and suppliers of demountable structures. It applies to demountable structures erected for events, whether or not the event is required to be licensed.

It is also intended for competent persons who are responsible for the design, erection, inspection and dismantling of demountable structures.

Demountable structures are usually assembled from readily connected components which, after

dismantling, may be reused many times. A number of proprietary systems exist which should be used in accordance with the manufacturer's instructions and in accordance with the approval of the local authority.

This *Guide* is concerned with the structural safety and adequacy of demountable structures used for temporary purposes and also with the overall planning and management of events. 'Temporary' is taken here to mean that the structure will not usually be in position for more than 28 days. This period of time is not definitive.

Layout, entry, exit and other requirements for crowd safety are covered in general terms only but information on sources of guidance on such requirements is provided.

1.3 Status of the Guide

The Institution of Structural Engineers has produced this *Guide* as guidance and it is only intended as such. It is not intended to provide the definitive approach in all situations. However, it is suggested that any departures should be carefully considered and the reasons for them should be recorded.

SECTION 2 PRINCIPAL RESPONSIBILITIES

This Section is intended for all readers

“Primary responsibility for the safety of people attending an event and of the users of temporary demountable structures lies with the client. The client cannot pass on the responsibility for safety to any third party.”

“The client should make sure that competent persons are employed to design, supply and erect the temporary demountable structures.”

“It is the responsibility of all those concerned with such structures to exercise care in their work and in all matters relating to the safety of the people who may be using them.”

2 PRINCIPAL RESPONSIBILITIES

2.1 General

The general requirements for health and safety relating to demountable structures are the same as for permanent structures: a demountable structure should be part of a safe and healthy environment for those using it, and should not give rise to risks to the health or safety of users, nor to those involved with erection, maintenance or dismantling of the structure. It is the responsibility of all those concerned with such structures to exercise care in their work and in all matters relating to the safety of the people who may be using them.

2.2 Responsibilities of clients, venue owners and event organisers

Primary responsibility for the safety of people attending an event and of the users of temporary demountable structures lies with the client. The client cannot pass on the responsibility for safety to any third party. The owner of the premises where the event is located also has responsibilities relating to safety.

The client should make sure that competent people are employed to design, supply and erect the temporary demountable structures. The client should make proper enquiries about competence and obtain written evidence of this. The client is responsible for the safety of users of temporary demountable structures in respect of management and control of users before, during, and after an event.

It is important that responsibilities for the safe procurement, erection, use and dismantling of demountable structures are clearly defined in writing at the outset so there is no misunderstanding of the roles of the client or any other party (Figure 1) (Also see Section 5).

The client should:

- Make sure that requirements for safety in use are met.
- Oversee, with appropriate monitoring, the procurement, including provision by the contractor of erection drawings accompanied by calculations, design loads and any relevant test results.

If the client does not have appropriate technical expertise, they should consider appointing a competent person to advise them who may act as the client's agent for the purposes of statutory compliance.

The appropriate authorities should be given adequate notice of the proposed use of the structure and be advised when it will be available for inspection before use. This is the responsibility of the client or their agent.

It is a requirement of the Management of Health and Safety at Work Regulations 1999^{2.1} for all employers to carry out a risk assessment (see Section 3.2).

The event organiser is responsible for overall safety co-ordination before and during the event (see Section 3.1).

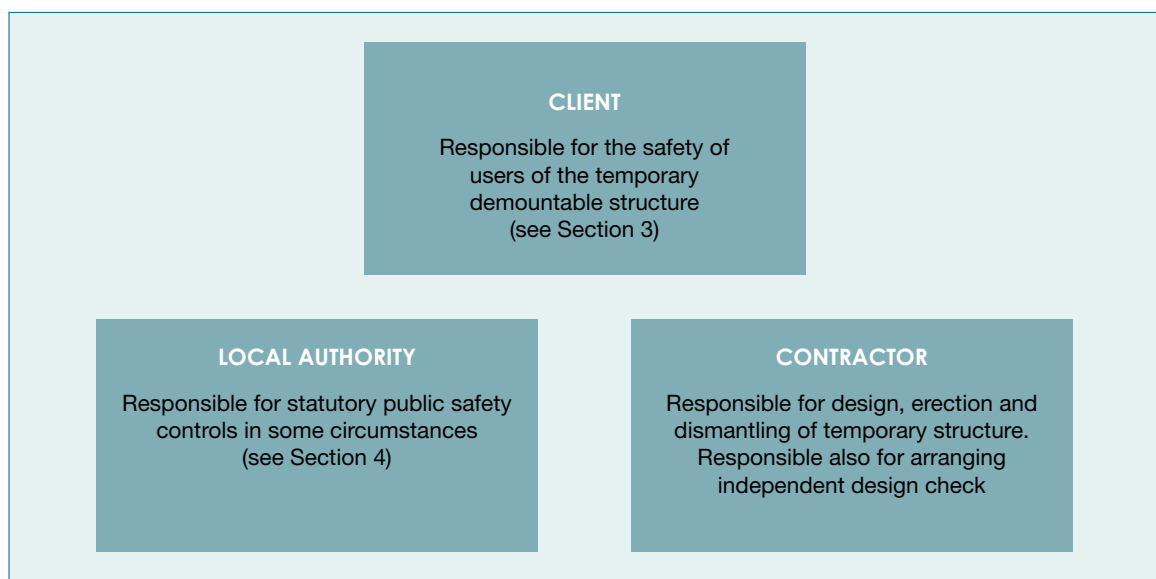

Figure 1 Principal responsibilities

Procedures for dealing with severe weather conditions during an event – particularly strong winds or heavy rain – should be in place. New guidance on wind loading on temporary structures is included in Section 8 of this edition of the *Guide*.

The 1995 edition of this *Guide* laid emphasis on the responsibilities of the client and the need for clients to recognise their responsibilities and employ competent persons who are adequately resourced. Contractors and suppliers of temporary demountable structures have, however, experienced little change of approach by clients and the responsibility for safety has been tacitly delegated to contractors and suppliers. This new edition recognises the reality of the present situation and Figure 1 is now presented in terms of responsibilities. The fact that clients' responsibilities cannot be passed on to third parties is noted here again.

Written method statements for erection and dismantling, including method of founding evenly on the ground, should be prepared by the contractor and given to the client for onward transmission to all relevant parties, including the local authority, if required.

2.3 Responsibilities of designers and contractors

It is only through assessing all the relevant scenarios that the designer or contractor can be sure that the risks of accidents have been considered.

This *Guide* recommends that when considering occupancy, means of access and means of escape, designers and contractors should familiarise themselves with the environmental and technical infrastructure of the site or building in which the temporary structure is to be erected, and its management and information systems. In particular, they should identify safety problems by evaluating the hazards and risks and make sure that temporary structures are properly designed with full regard to their surroundings. In all cases, a written risk assessment, including a fire risk assessment, should be completed.

All structures should be properly designed by a competent person. The designer should be able to provide evidence of their competence.

Structural safety and the safety of users should be considered on an equal basis. The installation of a temporary structure should not compromise the safety of the existing environment.

An increasing number of Eurocodes are becoming available in the period leading up to the publication of this *Guide*. It is important to understand that the material Eurocodes should not be mixed with British Standards for loading or geotechnical design (or vice versa). The Eurocodes can only be used with the appropriate UK National Annex as this defines a number of Nationally Determined Parameters (NDPs). Once all the Eurocodes and their National Annexes are available there will be a period of co-existence during which time designers could use either the Eurocodes or British Standards. However, conflicting British Standards will then be required to be withdrawn and from this date (scheduled to be March 2010 at the time of publication) designers should use the Eurocodes.

Independent design checks should be made of the design of temporary structures. Responsibility for arranging these checks rests with the contractor (see Section 5.1.4.).

The independent design check should be carried out by a chartered engineer having adequate skill and experience. The check may be made on a standard system (which may be based on design or have evolved on an empirical basis), or of the design of any special or non-standard arrangement of elements supplied for a project.

An independent erection check on the structure once it has been erected should be carried out by a competent person, who may be an employee of the supplier of the structure or a person nominated to carry out such checking by the contractor. Where the erection check is carried out by a member of the erection team, evidence of that person's competence should be made available.

2.4 References

Readers are advised to check for updates given to references throughout this document.

- 2.1 *Health and Safety: The Management of Health and Safety at Work Regulations 1999*. London: The Stationery Office. 1999 (SI 1999/3242)

SECTION 3

HAZARDS AND RISKS RELATING TO DEMOUNTABLE STRUCTURES

This Section is intended particularly for clients, designers and contractors

“All employers are required, under the Management of Health and Safety at Work Regulations 1999, to carry out an assessment to identify hazards and risks that could cause injury to employees or the public.”

“A structural means of providing a safe route from any part of a demountable structure to either a place of safety or a final exit (means of escape) is essential.”

“Crowds may impose significant vertical and horizontal loads on temporary structures and crowd behaviour in emergencies is also important.”

“To create a safety plan, the hazards and associated risks throughout the design, procurement, use and dismantling of a demountable structure should be assessed, and a plan for managing these should be prepared that includes the responsibilities of the various parties. The most important aspects of a safety plan are its actions and the management of these actions, i.e. a clear chain of responsibility or command.”

“It is particularly important therefore that proper consideration is given at the design stage to providing good sightlines.”

3 HAZARDS AND RISKS RELATING TO DEMOUNTABLE STRUCTURES

3.1 Hazards

The public expect safety in their normal environment and discount the risks which may be present. Hazards are generally defined as circumstances that have a potential to cause harm. Risks are the likelihood of the hazards being realised. The process of assessing hazards and risks may be summarised as:

- What if...?
- How likely?
- What consequences?

3.1.1 Design hazards

During the design process, hazards may unknowingly be incorporated in a structure. These may create a danger to the people erecting the structure, and to the users, if they are not detected. They are reduced by appropriate quality assurance and design checks. Such hazards may be due to errors on the part of the designer, e.g. non-compliance with current good practice, failure to appreciate operational requirements, or limitations in current knowledge.

The design team should include competent persons who understand the nature of the use to which the temporary demountable structure will be put.

3.1.2 Erection and dismantling hazards

During erection, hazards may be caused for a number of reasons including human error, time pressure, inadequate lighting, tired operatives and malfunction of equipment. Such hazards may present a danger to operatives erecting the structures and to users, if they are not detected. They are avoided by appropriate controls built into specifications and erection documents such as method statements, by training of operatives, by inspection and checking during erection, and by the final independent erection check (see Section 5.2.6). These hazards may also apply during dismantling.

The principal hazards to safety during erection and dismantling include:

- Non-compliance with design and erection documentation.
- Non-compliance with good practice.
- Power or equipment failure.
- External event, e.g. fire, explosion, vehicle impact, wind.

3.1.3 Operational hazards

When erection is complete and the facility is open to users, a different set of hazards exists. If the facility has been properly designed and erected then the hazards will generally be the result of external influences. Their effect will be minimised by preplanning at all stages. Principal operational hazards include:

Structural

- Overloading, structural failure or collapse.
- Vehicle impact.
- Extreme external events e.g. flood, wind, snow, earthquake, lightning.
- Structural damage from any cause.

Crowd behaviour

- Overcrowding.
- Vandalism or violent criminal behaviour.
- Excitement, demonstrations or incitement of a crowd.
- Fire or explosion.
- Power loss leading to systems failures.
- Spillage of dangerous substances.
- Medical emergencies.
- Accidents.

Each hazard should be considered on its own and in association with any secondary hazards. For example, an explosion may be followed by fire, power failure, overcrowding at exits and medical emergencies. Several scenarios are possible although many are highly improbable. The risks associated with a hazard or series of consecutive hazards should be assessed.

3.2 Risk assessment

All employers are required, under the Management of Health and Safety at Work Regulations 1999^{3.1}, to carry out an assessment to identify hazards and risks that could cause injury to employees or the public. The regulations also require self-employed people to carry out an assessment of their work practices. When significant changes are made to work procedures the regulations require these assessments to be reviewed. Where an employer employs five or more people any significant findings should be recorded and especially vulnerable people should be identified. The risks associated with a hazard depend upon a number of factors:

- The probability of an incident and a series of secondary events occurring.
- The effectiveness of measures to protect against the hazard and to control an incident.
- The direct consequences if an incident occurs and the indirect consequences afterwards.

Adopting a sensible approach to the likelihood of an incident, and taking precautions to maximise protection and to minimise the consequences, may also minimise the costs.

Assessing the consequences of an adverse incident is both a human and a commercial matter. The fact that disasters are remembered by the names of their location signifies that memories are long. It may take many years for a venue which has been the site of a major incident to recover its popularity and prosperity.

Direct consequences (e.g. death, injury, property damage) are followed by indirect consequences (e.g. financial losses, damage to reputations, increased insurance premiums). Recognising that very serious consequences follow any major incident promotes safe practices.

A number of individuals and organisations may be responsible for assessing risks at different stages in the life of a demountable structure, e.g. a competent person for design, and the event organiser for its use during an event. Their responsibilities for exercising skill and care in assessing risks are covered by the Management of Health and Safety at Work Regulations 1999^{3.1}, and by various contractual and tortious duties owed to all persons using the structures.

First, significant hazards for the structure should be identified (e.g. structural collapse, fire, overcrowding) and possible consequences (e.g. fatalities, injuries, financial losses). Risks are then assessed in the light of the identified hazards. To minimise risk, the likelihood of an incident occurring and the cost of control measures should be evaluated. Reasonably foreseeable hazards should be dealt with by reasonably practicable solutions. After this assessment has been made:

- The hazard should be removed where possible.
- The risk from the hazard should be minimised where its removal is not reasonably practicable.

Risk assessment should be based on past experience as far as possible, which means that records of performance should be kept, both for type of event and individual contractors. Information from people with previous experience of demountable structures, such as local authorities, emergency services, insurers, engineers, event organisers and facility managers, may be valuable. Useful guidance on risk assessment and related matters is given in Chapter 2 of the *Guide to Safety at Sports Grounds*^{3.2}.

It should be appreciated that it is not practicable to provide a generic checklist to cover all temporary demountable structures.

3.3 Steps to minimise risks

3.3.1 Design

The design of temporary structures should generally follow the recommendations in this *Guide*. Design documentation should be prepared which sets out the design criteria for the structures. The engineering documentation should include a clear summary of the design parameters and operating limits of the structure.

At the design stage a positive attitude to safety should be adopted: many potential hazards can be envisaged, the risks assessed and plans made accordingly. In some cases the risk may be so great that another solution is necessary. For example, in selecting the site for a temporary demountable structure, the presence of live overhead electricity cables, or difficulties of access for users, might indicate moving the event elsewhere. Hazards that may affect the safety of a structure should be recorded in a checklist or operation manual for use by the people controlling the structure during use.

Vehicle impacts on temporary structures, and the possibility of structural damage, fire, explosion or chemical spillage should be considered during design. Structures, particularly vulnerable parts, should be protected from vehicle impact or local damage that might lead to disproportionate collapse, where possible these hazards must be removed/eliminated (e.g. by traffic control means, bollards or earth mounds). Traffic should be separated from pedestrians as far as possible.

In parts of the world subject to seismic activity, the hazards associated with this should be considered. Guidance is available; see for example, EN 1998 Eurocode 8^{3.3} and ANSI E 1.21 Entertainment Technology – Temporary Ground-Supported Overhead Structures Used to Cover the Stage Areas and Support Equipment in the Production of Outdoor Entertainment Events New York ANSI 2006^{3.4}.

3.3.2 Erection and dismantling

Erection of demountable structures has its own hazards. Most of these primarily affect site operatives, but some may also affect users of the facility.

Safety margins may be eroded if recommendations in this *Guide* and other relevant guidance documents are not followed. Responsibility for erection should be made very clear, preferably by appropriate wording in the contract. Specifications need to be unambiguous and co-ordinated with the erection drawings.

All temporary structures should be of sound materials and good construction, i.e. properly put

together, and properly founded and supported. Partially erected (or dismantled) structures (Figure 2) may be more vulnerable to the consequences of some hazards, e.g. overloading, vehicle impact or instability due to wind loading.

If the contractor proposes alternatives to the agreed designs these should be approved by the client and the competent person responsible for the design. Such changes should be subject to a further independent design check. For standard designs, where the changes are within the scope of the original design, further checks may not be needed provided that the contractor has the appropriate quality assurance schemes in place detailing the methodology of operations, checking inspections and handover certificates.

Methods of quality control for site operations, including site inspections, should be established. Before opening a structure to users, an independent erection check should be carried out by a competent person (see Section 5.2.6). This is particularly important if the structure has been erected at short notice.

3.3.3 Operation

Once erection of a structure is complete and it is opened to the users, the hazards come from the location, external events and the way in which the operations, not just of the structure but also of the whole event, are

managed and controlled. Responsibilities are complex and those involved at various stages may include clients, local authorities, local health authorities and hospitals, police, fire brigade, and civil defence authorities.

A clear chain of responsibility and command should be specified for each section of the safety plan (see Section 3.6) and this may include matters that relate to the operation and use of a temporary structure. For example, the safety plan should take account of risks associated with matters such as power supply, overcrowding, vandalism or malicious tampering with the structure.

The operating limits defined in the engineering documentation should form the basis of the Operations Management Plan. This document defines the actions to be taken at certain times. For example, it would define the wind speed at which personnel would be put on standby to remove the wall scrim or equipment attached to a temporary stage roof structure. It would also define the higher wind speed at which these would actually be removed. Guidance is available^{3.4}.

3.4 Crowd behaviour

3.4.1 Introduction

Crowds may impose significant vertical and horizontal loads on temporary structures (see Section 9.3.2) and crowd behaviour in emergencies is also important. Reference should also be made to *The Event Safety*



Figure 2 A site in part-built mode

Guide – Guide to health, safety and welfare at music and similar events^{3.5} for advice on crowd behaviour. At the time of publication of this *Guide*, the *Event Safety Guide* was about to be updated and it is believed that further information on the deployment of barriers would be included. Readers are advised to check the latest edition.

Leisure events attract large numbers of people (Figure 3). A crowd may, by its density or mobility, create dangerous conditions in interaction with the local environment.

Visitors to an event assume that planning for their safety and welfare has taken place. There is, correspondingly a legal responsibility on the part of venue owners, event organisers and contractors to undertake such planning.

3.4.2 Crowds

The density of a crowd determines the amount of free space available to individuals. Where free space is available around each person, even in a very large crowd, people will be comfortable. The critical issue therefore, is usually the local crowd density, rather than the overall capacity of the facility.

If the crowd density increases and involuntary body contact occurs, people cannot move easily and they may become tense. If the tension is further raised, either deliberately by the event they are watching, or by a serious incident such as an explosion, then the collective mood of the crowd changes. It can become very difficult to pass safety information to the crowd in these circumstances.

Control is needed when the behaviour of individuals in the crowd changes. Crowd density should therefore be considered during the design stage. During the event, there should be an efficient means of controlling the occupancy of local areas.

At different stages during an event, crowds may behave in a variety of ways. They may be:

- Voluntarily ambulatory at access, egress and during an event.
- Voluntarily ambulatory because of migration to an area with better sightlines, creating local overcrowding.
- Involuntarily ambulatory because of dynamic forces within large crowds.
- Non-ambulatory, standing waiting to enter or leave the event or standing as passive spectators.



Figure 3 A large crowd

Ambulatory crowds occur at events where there is frequent movement around the site, e.g. racing meetings, golf tournaments, markets, exhibitions (Figure 4). At these events, people attend for relaxation and are amenable to instructions given through information and management systems in non-threatening circumstances.

Spectators, particularly at such events, appreciate good access, egress and viewing facilities with no local overcrowding. Because they are not in a high state of stimulation, they respond well to both visual and verbal information systems. They may make several journeys to and from various parts of the site during an event. A temporary grandstand may be emptied and reoccupied frequently.

In non-ambulatory crowds, spectators take up fixed viewing positions and generally remain at the same location, apart from visits to refreshment facilities, toilets, etc. Examples of events which attract these types of crowd are concerts and sporting competitions. Although these crowds may similarly appreciate safety and comfort provisions, they may not be so receptive to visual or verbal information systems. This may be because of increased stimulation due to a combination of high ambient noise levels, excitement generated by the performance and the effects of crowding in itself. In such conditions, evacuation information needs to be very intrusive indeed. These crowd conditions can become very difficult to control if public order disturbance occurs simultaneously.

Sightlines have a critical effect upon crowd behaviour. Poor or obstructed sightlines can lead to seated spectators standing and becoming agitated because they cannot see and this can lead to adverse crowd behaviour. Standing up in a seatway is not in itself dangerous, but it may lead to people standing on seats, which is particularly hazardous. In stands that are not fully occupied, audience migration may also occur over seatways, which can lead to injury.

It is particularly important therefore that proper consideration is given at the design stage to providing good sightlines. Guidance is available from the Football Licensing Authority publications and in Chapters 11 and 12 of the *Guide to Safety at Sports Grounds*^{3.2}.

3.4.3 Crowd control or crowd management

Crowd control implies that crowds are intrinsically dangerous. They are not: they are simply made dangerous by insufficient or inappropriate provision for their demands. A physical response by stewards is then necessary to secure public safety.

By contrast, crowd management is the business of recognising, analysing and meeting the demands of crowds by a combination of forward planning, risk assessment, engineering response, visually intrusive and clearly audible information and alert general management. The aim should be to make crowd control unnecessary by the implementation of good crowd management.



Figure 4 An ambulatory crowd

3.5 Fire

In assessing fire safety, designers should consider the distinction between life safety provision and provision which protects property. The requirement for proper safety measures will inevitably impact upon the work of a designer, in particular in the safe and cost-effective choice of materials. However, decisions should always be taken within the context of life safety provision including safe evacuation from the demountable structure.

A structural means of providing a safe route from any part of a demountable structure to either a place of safety or a final exit (means of escape) is essential. There should also be an alternative means of escape of no less a standard. Such means of escape from a demountable structure should be integrated into the emergency exit system of the site or building in which it is situated. There should be enough exits to evacuate it within a specified time^{3.2, 3.6}. The local fire authority should be consulted to assist with assessing occupancy factors of demountable structures.

Research has shown that traditional approaches to evacuation have incorrectly assumed that people panic in fire incidents^{3.7}. Far from panicking, people tend to wait inquisitively and watch the fire develop. Furthermore, they dangerously underestimate the rapid spread of a developing fire. Emphasis has therefore shifted to the time taken for crowds to move^{3.8}. This problem may be best dealt with by information and management systems, such as public address systems and effective stewarding, rather than traditional alarm bells or sirens. These systems do not replace traditional engineering responses, but are an important complementary feature of safety management.

Other factors may affect the ability of people attempting to evacuate a temporary structure. Inhalation of carbon monoxide, carbon dioxide and cyanide gas, which are readily produced in most fires, can be fatal. Furthermore, smoke irritants from burning organic and inorganic materials cause difficulty in seeing and breathing, and delay evacuation. Choice of materials can therefore be critical to life safety in a rapidly developing fire even though traditional detection and alarm systems are in place.

The aim of designers, contractors and those responsible for safe management of the demountable structure should be to eliminate:

- Ignition sources, e.g. matches, smoking materials, flame from cooking fuels, flame caused by electrical circuit failure.

- Rubbish that will ignite easily, e.g. accumulations of waste paper or wood shavings.
- Combustible material that will contribute to a rapidly developing fire and produce toxic gases and dense smoke, e.g. thin untreated wooden sheets or untreated drapes or curtains.

Designers and contractors should consider fire risks which are reasonably foreseeable and should aim to eliminate or reduce risks to a level which is considered acceptable. During a fire risk assessment the following checklist may help in identifying materials or activities which might contribute to the development of a serious fire:

- 1 Are structural members made of combustible material likely to prejudice the safety of people using the structure? If inferior materials are used, available evacuation time may be significantly reduced. The use of incombustible construction materials is the primary protection for people against fire in demountable structures ^{3.2, 3.6}.
- 2 Could rubbish accumulate under the structure?
- 3 Could timber, used as decking, risers, soffits or balustrades, make a significant contribution to a developing fire?
- 4 Does decorative laminate used to face the timber elements (in (3) above) have an acceptable resistance to surface spread of flame?^{3.9}
- 5 Have design and construction of the structure provided acceptable travel distances, evacuation times and alternative means of escape?^{3.2}
- 6 Could seating materials contribute to the rapid spread of fire?
- 7 Are curtains, hangings or decorations made of flame-retarded, durably flame-retarded or inherently flame-retarded fabric?^{3.10, 3.11}
- 8 If a structure is erected indoors, can existing automatic fire detection, fire suppression or fire alarm systems^{3.12,3.13} make a significant contribution to fire safety?
- 9 Does the venue have a general management and stewarding response which is alert to fire hazard?
- 10 If a fire started, could hot gases accumulate beneath the roof of a temporary structure?
- 11 Have measures to provide smoke ventilation been considered to prevent flashover?
- 12 Can kiosks beneath grandstands be effectively 'fire separated'? If kiosks are used as unoccupied store rooms during an event, are fire detection systems in place? How and to where are the kiosks ventilated?

In addition to the above, consideration should be given to the choice of materials, with particular regard to those that might give off toxic gases when subjected to fire conditions or highly elevated temperatures.

The contribution to fire safety provided at a site or indoor venue by the existing infrastructure may vary considerably. Where the contribution is significant it may be possible to relax other requirements. However, designers and contractors are cautioned about reliance solely upon management control of the event to reduce life safety risks in fire assessments. Such solutions may be beyond the scope of the designer or contractor to verify, e.g. the quality of stewarding.

Flammable gases are not permitted in many public assembly buildings. At outdoor sites, however, they are a popular cooking fuel. Butane and propane, collectively known as liquefied petroleum gas or LPG, are used extensively. The gas is 1.5 times heavier than air and forms a flammable mixture at between 2% and 10% by volume in air. Temporary hoses and connections may be susceptible to damage and leakage. LPG could represent a significant risk of fire and explosion should it accumulate beneath a temporary structure. It is recommended that the storage or use of LPG should not be permitted beneath demountable grandstands. Furthermore, cooking methods that give rise to serious risk of fire, such as deep fat frying, should not be permitted beneath these structures. Any LPG stored in the vicinity of such a structure should comply with advice in reference 3.14.

3.6 Safety planning

3.6.1 Introduction

Demountable structures used by large numbers of people do not exist in isolation. They should be designed and erected with full regard to the local environment and the needs of users. To achieve the safety of the temporary structure and its occupants, the structure should be designed and erected in such a way that it is coordinated and integrated with the safety framework of the venue or site and so that it responds predictably to its particular usage.

The historical engineering response to safety is well understood. However, controlling the planning and supervision of the design, procurement and use of demountable structures at events, is less well known. Preparing and implementing a safety plan, which identifies the hazards and associated risks relating to the design, procurement and use of the proposed structure within the context of the event, is an effective means of achieving such control.

3.6.2 The safety plan

To create a safety plan, the hazards and associated risks throughout the design, procurement, use and dismantling of a demountable structure should be assessed, and a plan for managing these should be prepared that includes the responsibilities of the various parties (see Sections 3.1 and 3.2). The most important aspects of a safety plan are its actions and the management of these actions, i.e. a clear chain of responsibility or command. Individuals should be both identifiable and accountable in respect of their responsibilities for safety matters.

The safety plan should deal with any special requirements shown on the drawings and other documentation.

Security staff should be trained for emergencies and new and temporary staff given training and instructions. The safety plan, together with drawings of the venue facilities, should be held by the safety coordinator and should be immediately available if an incident occurs, for those in command and the emergency services.

Guidance on management and operation of events is given in the *Guide to Safety at Sports Grounds*^{3.2}, *The Event Safety Guide*^{3.5} and the *Guide to fire precautions in existing places of entertainment and like premises*^{3.6}.

The degree of risk never remains static but changes as patterns of behaviour change. Safety plans should be subject to continual review and periodic formal revision. The plan will benefit from input from facility operators and should be periodically reviewed for repeated events. Feedback from debriefing meetings after the event can be very useful in assessing the operational effectiveness of the safety plan.

3.7 References

Readers are advised to check for updates given to references throughout this document.

- 3.1 *Health and Safety: the Management of Health and Safety at Work Regulations 1999*. London: The Stationery Office, 1999 (SI 1999/3242)
- 3.2 Department of National Heritage and Scottish Office. *Guide to safety at sports grounds*. 4th ed. London: The Stationery Office, 1997
- 3.3 *BS EN 1998-1: 2004: Design of structures for earthquake resistance – General rules, seismic actions and rules for buildings*. London: BSI, 2005

- 3.4 *ANSI E1.21–2006: Entertainment technology: temporary ground-supported overhead structures used to cover the stage areas and support equipment in the production of outdoor equipment in the production of outdoor entertainment events.* New York: ANSI, 2006
- 3.5 Health and Safety Executive. *The event safety guide: guide to health, safety and welfare at music and similar events.* London: HSE, 1999 (HSG 195)
- 3.6 Home Office and Scottish Home and Health Department. *Guide to fire precautions in existing places of entertainment and like premises.* London: The Stationery Office, 1990
- 3.7 BRE. *Human behaviour in fire.* Garston, BRE, 1993 (BRE Digest 388)
- 3.8 Proulx, G., and Sime, J. D.: *To prevent 'panic' in an underground emergency: why not tell people the truth?* in: Cox, G. and Langford, B. *Fire safety science: 3rd international symposium.* London: Elsevier Applied Science, 1991
- 3.9 *BS 476: Fire tests on building materials and structures.* [several parts]
- 3.10 *BS 5867-2: 1980: Specification for fabrics for curtains and drapes. Flammability requirements.* London: BSI, 1980
- 3.11 *BS 5438: 1989: Methods of test for flammability of textile fabrics when subjected to a small igniting flame applied to the face or bottom edge of vertically orientated specimen.* London: BSI, 1989
- 3.12 *BS 5839: Fire detection and fire alarm systems for buildings.* [several parts]
- 3.13 *BS 5306: Fire extinguishing installations and equipment on premises.* [several parts]
- 3.14 LP Gas Association. *Code of practice 7: storage of full and empty LPG cylinders and cartridges.* Ringwood: LP Gas Association, 2004 (CoP7)

SECTION 4 STATUTORY CONTROL

This Section is intended particularly
for clients and local authorities

“It is important that venue owners and event organisers make early contact with the local authority to establish what procedures should be followed for notification and what technical standards will need to be met.”

“... in most cases, clients, venue owners and event organisers, rather than the suppliers of temporary demountable structures, are principally responsible, in law, for complying with public safety legislation while the structure is in use. It should also be borne in mind that penalties for non-compliance can be severe.”

4 STATUTORY CONTROL

4.1 General

This Section outlines the current legislation most likely to apply to temporary demountable structures. The situation is complex and is regarded by many as less than satisfactory from a public safety point of view. In many cases, legislation has evolved as a result of recommendations made in the aftermath of accidents and disasters (especially as far as sports grounds are concerned) and it is important that venue owners and event organisers make early contact with the local authority to establish what procedures should be followed for notification and what technical standards will need to be met.

It should be noted that, in most cases, clients, venue owners and event organisers, rather than the suppliers of temporary demountable structures, are principally responsible, in law, for complying with public safety legislation while the structure is in use. It should also be borne in mind that penalties for non-compliance can be severe.

It is therefore recommended that venue owners and event organisers involved in the procurement of temporary demountable structures should contact the local authority's building control or environmental health office, at the earliest opportunity, to obtain guidance about technical and procedural requirements relating to such structures.

The local authority is generally responsible for safety regulation. However, where another agency, or indeed another department of the local authority, is responsible, either the building control officer or the environmental health officer should be able to make sure that enquiries are directed to the appropriate body.

Local authorities should make clear from the outset what legislation applies in any particular case and exactly what procedural requirements have to be followed by people proposing to erect temporary demountable structures for public use.

A number of factors will determine what legislation will apply, as explained later. Building control officers (or whichever local authority department is responsible for public safety regulation) will expect to be furnished with information about the proposed use of the structure and the length of time it is to remain on site in order to advise venue owners and event organisers on compliance with the relevant statutory requirements. Readers are advised to check for updates to the many references given throughout this document.

4.2 Building Regulations

4.2.1 England and Wales

Building Regulations^{4.1} apply to all new buildings erected in England and Wales, save for specific exemptions contained in a Schedule attached to the Regulations. However, many temporary demountable structures will not be subject to control under Building Regulations because either:

- They will not be classed as a 'building' for the purposes of the Regulations; or
- They will be covered by one of the categories for exemption listed in the Schedule.

For instance, in most cases, an uncovered stand is unlikely to fall within the definition of 'building' in the Regulations, which is necessary if it is to be subject to control, whereas it is likely that a covered (or part-covered) stand will. Separately, under current provisions, most temporary buildings which will remain on site for less than 28 days will be exempt under Schedule 2 of the Regulations. In all cases, however, the advice of the local authority's building control officer should be sought.

Where the Building Regulations apply, prior notice of the erection of the structure should be given to the local authority, together with sufficient details for them to check whether it complies with all of the relevant requirements in the Building Regulations (including structural stability and fire safety). The local authority may also carry out site inspections during erection to make sure that the finished building complies with the Regulations. A fee will be charged by the local authority for this service.

4.2.2 Scotland

The Building (Scotland) Regulations^{4.2,4.3,4.4} apply to all new buildings in Scotland, save for specific exemptions stated in Regulation 3, Schedule 1 and Regulation 5, Schedule 3.

The definition of 'building' in Scotland does not exclude temporary demountable structures, including uncovered stands. Temporary structures either erected or used for a period not exceeding 28 days, or 60 days in any 12 months, are however exempt.

4.2.3 Northern Ireland

As in England and Wales, Building Regulations^{4.5} apply to all new buildings, save for specific exemptions stated in Part A: Regulation A5. The definition of 'building' in Northern Ireland includes a temporary building, structure or erection of whatever kind or nature. Temporary structures erected for a period not exceeding 28 days are exempt as defined in Regulation A5(1), Schedule 1 Class 4.

4.3 Planning permission

It is impossible to summarise here the circumstances under which planning permission will be necessary for the use of temporary demountable structures on any given site in England, Wales or Scotland. However, it is advisable for the event organiser to seek the advice of the local authority's planning office prior to the erection of the building or structure. Clearly, planning control will not directly address public safety issues; however, constraints affecting the siting of the building, permitted hours of use, etc. may alter the number of hazards.

The advice given above is equally applicable to Northern Ireland. In Northern Ireland 'planning' is the responsibility of the Government of Northern Ireland and is administered by the Planning Service, an agency within the Department of the Environment for Northern Ireland.

4.4 Premises licensed for public entertainment (not including sports grounds)

4.4.1 England and Wales

The Licensing Act 2003^{4.6} empowers local authorities to issue licences in connection with premises used for public entertainments purposes. The act has streamlined the previous regime and brought all places of entertainment under one licensing act. Temporary demountable structures, including barriers, have no specific mention under the legislation. However to ensure a premises licence is approved the licensing authority can attach conditions to the premises licence.

As for Building Regulation control, it should be noted that it is usually the responsibility of venue owners and event organisers to make the necessary application to the local authority.

The description of regulated entertainment that needs to be licensed before any premises may be used for such purposes is outlined as follows.

- A performance of a play.
- An exhibition of a film.
- An indoor sporting event.
- A boxing or wrestling entertainment.
- A performance of live music*.
- Any playing of recorded music*.
- A performance of dance*.
- Entertainment of a similar description to that falling within points marked * above where the entertainment takes place in the presence of an audience and is provided for the purpose, or for purposes which include the purpose, of entertaining that audience.

The definitions of 'entertainment' and 'premises' for licensing purposes are important in determining whether statutory provisions will apply. The definitions as outlined above are precisely given within the act.

The few exemptions that are made under the act come under Schedule 1 Part 2 and include:

- For the purposes of, or incidental to, a religious meeting or service.
- At a place of public religious worship.

It is generally held that, if the public (or any section of the public) are allowed to attend an entertainment, whether on payment or otherwise, the entertainment is public. Other considerations, such as whether admission is by ticket or programme (and whether the tickets or programmes have been sold beforehand, been advertised, or are in aid of charity) are immaterial.

As the licence applies to the premises itself, even if the event can be seen as not open to the public the conditions attached to the premises will remain in force.

Private clubs also fall under the new licensing act and as such are regulated in a similar manner.

The term 'Premises' includes parks and open spaces not just buildings.

Under the 2003 Act a *Temporary Event Notice* (TEN) can be applied for that allows an event with no more than 499 people present to take place for no longer than 96 hours.

If the notice is applied for correctly there can be no attached conditions by parties such as building control, and although normal Health and Safety law applies it might appear that no other statutory control will be in place.

This may prove to be more of a concern to the reader of this *Guide*, as the only people allowed to object or apply conditions are the Police.

In all cases, contact with the local authority and enforcing authority should be made to ascertain the effects of these provisions on the erection of temporary structures for use in connection with public entertainment.

4.4.2 Scotland

The Civic Government (Scotland) Act 1982^{4.7} empowers local authorities to issue licences in connection with premises used for public entertainment purposes (Section 41 of that Act refers), where on payment or payment of money's worth, members of the public are admitted.

Temporary grandstands and other raised structures (platforms, stands, staging, etc.) are subject to local authority approval under Section 89 of the Civic Government (Scotland) Act 1982. It should be noted that Section 89 does not apply to any structure in respect of which a building warrant has been granted.

4.4.3 Northern Ireland

The Local Government (Miscellaneous Provisions) (NI) Order 1995^{4.8} empowers district councils to issue licences in connection with premises used for entertainment purposes. Temporary demountable structures used in connection with entertainments will be subject to control under such a licence.

The types of entertainment that need to be licensed before any premises may be used for such purposes are:

- A theatrical performance.
- Dancing, singing or music, or any entertainment of a like kind.
- A circus.
- Any entertainment which consists of, or includes any public contest, match, exhibition or display of:
 - boxing, wrestling, judo, karate or any similar sport
 - billiards, pool, snooker or any similar game
 - darts, and
 - any other sport or game prescribed by the Department of the Environment for Northern Ireland.
- Machines or equipment for entertainment or amusement, excluding gaming machines[†].
- Equipment for the playing of billiards, pool, snooker or other similar games[†].

Note

Music or singing when part of a religious service is exempt under the Order.

The Order also applies to musical entertainment in the open air, and similarly identifies the different requirements for indoor and outdoor licences.

The Order stipulates that a licence is required, in relation to the provision of indoor entertainment, at any place where, on payment of a charge:

- People are admitted for the purposes of entertainment
- Meals or refreshments are supplied to the public, or
- Persons may use equipment mentioned in those items marked [†] above for entertainment.

The district council's building control surveyor will advise on any of the above matters, or will otherwise pass on enquiries to the relevant department.

4.5 Sports grounds

4.5.1 Sports grounds safety certification

The safety of spectators at sports grounds in England, Wales and Scotland is provided for under the Safety of Sports Grounds Act 1975^{4.9} or the Fire Safety and Safety of Places of Sport Act 1987^{4.10}. The main feature of control under this legislation is the issue of Safety Certificates which, like entertainment licences, include terms and conditions for the safe use of such venues. Safety criteria and procedural requirements for erection and use of temporary demountable structures at sports grounds will vary according to which Act applies to the sports ground in question, as explained in the following paragraphs.

Requirements will depend on whether safety provisions are prescribed by the Safety of Sports Grounds Act 1975^{4.9} (generally for larger sports grounds) or the Fire Safety and Safety of Places of Sport Act 1987^{4.10} (smaller venues). Guidance on the legislative procedures under the 1975 and 1987 Acts is given in Football Licensing Authority document *Safety Certification*^{4.11}. A Safety Certificate issued pursuant to the 1975 Act will generally prescribe terms and conditions relating to the whole of a sports ground (including areas such as open terraces, car parks, turnstile blocks, floodlight towers and club-houses) – known as a 'designated ground' whereas a Certificate issued under the 1987 Act will provide only for the safety of spectators occupying individual stands at a non-designated sports ground. Covered or part-covered stands with a capacity of 500 spectators or more will be 'regulated' under the 1987 Act.

The reasons for this variation in control relate to the fact that the different Acts arise from recommendations made in different public inquiries into disasters at football grounds: the 1975 Act follows Wheatley's report^{4.12} of the disaster at Ibrox Park, Glasgow in 1971; the 1987 Act results from Poplewell's report^{4.13} of the fire at Bradford City Football Club in 1985.

The erection of temporary demountable structures (or any alterations made to such structures) within the boundaries of a designated ground will always require prior notification to the Local or Enforcing Authority.

Alterations to the fabric of a regulated stand (which may be a covered temporary stand) or indeed any extensions or additions to a regulated stand will require similar notice to be given. The erection of temporary demountable structures at non-designated sports grounds, remote from any regulated stand, may not however fall subject to control under either Act (although the Building Regulations may still apply)

– in such circumstances the extent of the ‘control’ over public safety matters that can be exercised by a local authority are limited to the use of Prohibition Notices (see below) or the 1890 Act mentioned in Section 4.6.

The erection of a covered temporary stand at a non-designated sports ground will be subject to control under Building Regulations as outlined above. Additionally, if the stand will be capable of holding 500 people or more, the owner (or ground manager, or whoever else is in charge of events at the ground) should also apply to the certifying local authority for a Safety Certificate, before the stand is first used.

Guidance for local authorities on preparing and issuing safety certificates for designated grounds and regulated stands is given by the District Surveyors’ Association^{4.14, 4.15}.

Table 1 shows the general position as far as statutory public safety controls affect the erection of temporary grandstands. This simplifies the position somewhat and event organisers are advised to confirm, with reference to the local authority, whether a submission of details under Building Regulations will be required or whether an application for a new (or an amendment to an existing) Safety Certificate should be made. For instance, as far as ‘designated grounds’ are concerned, it should be noted that some association football grounds are designated under the 1975 Act even though their maximum ‘certificated’ capacities are less than 10,000.

The equivalent legislation in Northern Ireland for sports grounds is Safety of Sports Grounds (Northern Ireland) Order 2006^{4.16}.

<i>(Where)</i>	Designated sports grounds (most large sporting venues with spectators capacities 10,000+)				Other sports grounds^d (including sports grounds with ‘regulated stands’)			
	On site for less than 28 days		On site for 28 days or more		On site for less than 28 days		On site for 28 days or more	
<i>(How long)</i>	B Regs	S Cert	B Regs	S Cert	B Regs	S Cert	B Regs	S Cert
<i>(What)</i>	B Regs	S Cert	B Regs	S Cert	B Regs	S Cert	B Regs	S Cert
Uncovered grandstand accommodating < 500 spectators	No	Yes	No	Yes	No	No	No	No
Uncovered grandstand accommodating 500+ spectators	No	Yes	No	Yes	No	No	No	No
Covered (or part-covered) grandstand accommodating < 500 spectators	No	Yes	Yes	Yes	No	No	Yes	No
Covered (or part-covered) grandstand accommodating 500+ spectators	No	Yes	Yes	Yes	No	Yes	Yes	Yes

Notes

a B Regs – Building Regulations
b S Cert – Safety Certificate
c ■ Grandstands not subject to Building Regulations and not requiring a Safety Certificate
d This table may also be used to determine whether Building Regulations will apply in the case of other venues where grandstands are used for non-sporting events. For sites other than sports grounds the ‘Safety Certificate’ column can be disregarded

4.5.2 Sports grounds prohibition notices

Advice is given to local authorities in England, Wales and Scotland in Department of National Heritage circular SARDC1^{4.17} relating to the use of Prohibition Notices at sports grounds. This gives local authorities emergency powers to prohibit, or limit, the admission of spectators into a temporary structure at a sports ground where the local authority consider that there is a risk to public safety. A Prohibition Notice may be issued for parts of a sports ground not covered by a Safety Certificate, such as a temporary demountable structure. It should be noted that this may be the only form of control that can be exercised over, for instance, large uncovered temporary grandstands at non-designated sports grounds.

Like the 1890 Act discussed below, no prior notice needs to be given, by law, to the local authority before erecting a temporary grandstand, or similar structure, in a non-designated sports ground. However, in order to avoid the service of a Prohibition Notice, venue owners and event organisers should consult the local authority before procuring temporary structures for use in any part of a sports ground.

There is no separate legislation for sports grounds currently applicable in Northern Ireland.

4.6 Public Health Acts Amendment Act 1890

Symptomatic of the problems affecting statutory control over public safety is the fact that regulators in England and Wales are advised by Government to use this relic of Victorian legislation^{4.18} where other provisions fail to provide effectively for the safety of spectators at public events. Anyone minded to be critical of inconsistencies in interpretation of safety requirements would do well to appreciate that, if all else fails, recourse to statutory provisions as diverse and unhelpful as this one has to be made.

Section 37 of the above Act remains in force and states as follows:

‘Safety of platforms, etc., erected or used on public occasions

- (1) Whenever large numbers of persons are likely to assemble on the occasion of any show, entertainment, public procession, open air meeting, or other like occasion, every roof of a building, and every platform, balcony, or other structure or part thereof let or used or intended to be let or used for the purpose of affording

sitting or standing accommodation for a number of persons, shall be safely constructed or secured to the satisfaction of the surveyor of the urban authority.

- (2) Any person who uses or allows to be used in contravention of this Section, any roof of a building, platform, balcony or structure not so safely constructed or secured, or who neglects to comply with the provisions of this Section in respect thereof, shall be liable to a penalty not exceeding level 3 on the standard scale.’

Note

‘Urban authority’ can now be taken to mean the local authority.

Clearly, this Act can be used as a catch-all in the event that temporary demountable structures cannot be classified under any more recent provisions. It is considered that this provision is enforceable and applicable in England and Wales, whether or not the temporary grandstands or other structures mentioned in Section 37 are subject to the control of any other National and/or Local Act. However, there are certain circumstances where this Act would not apply. This is specifically provided for in Section 9 of the Safety of Sports Ground Act 1975^{4.9} and Section 33 of the Fire Safety and Safety of Places of Sports Act 1987^{4.10} (see Section 4.5.1). It should be noted that failure to comply with the provisions of Section 37 of this Act constitutes a criminal offence.

The 1890 Act does not require that prior notice be given to the local authority before erecting a temporary grandstand, or similar structure, but in order to avoid the worst consequences of this Act, venue owners and event organisers should consult the local authority before procuring temporary structures for use in connection with any purposes mentioned in this Section.

4.7 Local acts in England and Wales

In some areas of the country, local legislation (such as County Council Acts) will include public safety provisions which might affect the use of temporary demountable structures. The effect of local Acts in England and Wales is diminishing as they are being either repealed or superseded by national legislation, but reference should again be made to the local authority to establish any particular requirements that may apply due to the existence of such legislation.

Legislation in Inner London includes many provisions which are unique to this part of the country. For instance, Section 30 of the London Building Acts (Amendment) Act 1939^{4.19}, as amended by the Local Government Reorganisation (Miscellaneous Provisions) (No 4)^{4.20} order SI 1986/452, applies in Inner London (consent to special and temporary buildings, etc.). This Section applies to stands inside and outside buildings. (Inner London is the area comprising the Corporation of London, the City of Westminster, the Inner and Middle Temples and the Inner London boroughs: Camden, Greenwich, Hackney, Hammersmith and Fulham, Islington, Kensington and Chelsea, Lambeth, Lewisham, Southwark, Tower Hamlets, Wandsworth, and Westminster.)

4.8 Fire precautions

Reference should be made to the fire authority and the local authority for the appropriate provisions.

4.9 Health and Safety at Work etc. Act 1974

The Health and Safety at Work etc. Act 1974^{4.21} applies to all work activities and all involved in work activities have legal responsibilities for health and safety. Local authority environmental health officers will usually be responsible for enforcing the various requirements of the Act which relate to temporary demountable structures.

Regulations made under the Act give employers a duty to take steps to safeguard the health, safety and welfare of employees and others such as visitors, contractors and members of the public.

Employees similarly have responsibilities for their own health and safety and for the health and safety of others that may be affected by their actions. Importantly, employers' duties extend to people other than employees and include spectators and members of the public. The Health and Safety Executive or the environmental health department of the local authority will be able to advise on the application of this legislation in any particular case.

Designers and contractors should be aware that Section 6 of the Health and Safety at Work etc. Act 1974 places duties on those who design, manufacture or supply articles for use at work to carry out all testing, research and calculations to check that they are safe to use.

The Management of Health and Safety at Work Regulations 1999^{4.22} now place greater emphasis on risk assessments and other provisions contained in this legislation to make sure that suitable and sufficient

health and safety requirements are being met, not only in relation to the duty to audiences or spectators under Section 3 of the Act, but also in respect of the occupational safety of workers in industry. It may be that, as clients and local authorities become more familiar with the idea of risk assessments, they will require more detailed evidence of it.

Regulations made under the Health and Safety at Work etc. Act 1974 affect the work activities of those involved in the erection and dismantling of temporary demountable structures. For example, the Management of Health and Safety at Work Regulations 1999 require that employers carry out risk assessments, employ competent persons to advise on health and safety matters and provide adequate training to employees.

Documented health and safety policies and procedures should be maintained and method statements should be prepared detailing the erection and dismantling operations for temporary structures. There are a number of other regulations which relate to construction and cover safe working practices for operatives involved in the erection and dismantling of temporary demountable structures. Either the local authority's environmental health officers or the Health and Safety Executive will be able to give exact advice in this respect.

Equivalent requirements apply in Northern Ireland under the Health and Safety at Work (NI) Order^{4.23} and the Management of Health and Safety at Work Regulations (NI)^{4.24}.

Much legislation is applicable to temporary structures as well as to permanent structures, such as The Reporting of Injuries, Diseases and Dangerous Occurrences Regulations 1995 (RIDDOR)^{4.25}, which were re-enacted since the first edition of this *Guide* was published.

The Health and Safety Executive^{4.26} have stated that the (1994) Construction (Design and Management) Regulations^{4.27} do not apply to temporary demountable structures. Subsequent guidance has confirmed this^{4.28}.

4.10 References

Readers are advised to check for updates given to references throughout this document.

- 4.1 *The Building Regulations 2000*. London: HMSO, 2000 (SI 2000/2531)
- 4.2 *Building (Scotland) Regulations 2004* [s.1.]: The Stationery Office 2004 (SSI 2004/406)
- 4.3 *Building (Scotland) Amendment Regulations 2006*. [s.1.]: The Stationery Office, 2006 (SSI 2006/534)

- 4.4 *Building (Scotland) Amendment Regulations 2007*. [s.l.]: The Stationery Office, 2007 (SSI 2007/106)
- 4.5 *Building Regulations (Northern Ireland) 2000*. [s.l.]: The Stationery Office, 2000. (Statutory Rules of Northern Ireland 2000/389)
- 4.6 *Licensing Act 2003: Chapter 17*. London: The Stationery Office, 2003
- 4.7 *Civic Government (Scotland) Act 1982: Chapter 45*. London: The Stationery Office, 1982
- 4.8 *Local Government (Miscellaneous Provisions) (Northern Ireland) Order 1995*. [s.l.]: The Stationery Office, 1995 (SI 1995/759 (N.I.5))
- 4.9 *Safety of Sports Grounds Act 1975: Chapter 52*. London: HMSO, 1975
- 4.10 *Fire Safety and Safety of Places of Sport Act 1987: Chapter 27*. London: HMSO, 1987
- 4.11 *Football Licensing Authority. Safety Certification*. Available at <http://www.flaweb.org.uk/docs/specsafe/pubs/safecert.php> (Accessed: 19 February 2007)
- 4.12 *Report of the Inquiry into Crowd Safety at Sports Grounds by the Rt Hon. Lord Wheatley*. London: HMSO, 1972
- 4.13 *Report of the Inquiry into Crowd Safety and Control at Sports Grounds: Final Report by the Mr Justice Popplewell*. London: HMSO, 1985
- 4.14 London District Surveyors' Association. *Specimen safety certificate and guidance notes incorporating the 4th edition Green Guide revisions*. London: LDSA, 2004 (Safety of Sports Grounds no. 1)
- 4.15 London District Surveyors' Association. *Specimen safety certificate and guidance notes for regulated stands*. London: LDSA, 1996 (Safety of Sports Grounds no.5)
- 4.16 *Safety of Sports Grounds (Northern Ireland) Order 2006*. [s.l.]: The Stationery Office, 2006 (SI 2006/313 (N.I.2))
- 4.17 Department of National Heritage. *Safety of Sports Grounds Act 1975: prohibition notices*. (DNH Circular SARDC1, 1995). Available at: <http://www.flaweb.org.uk/docs/specsafe/pubs/dcms1995.php> (Accessed: 19 February 2007)
- 4.18 *Public Health Acts Amendment Act, 1890: Chapter 59*. London: HMSO, 1890
- 4.19 *London Building Acts (Amendment) Act 1939: Chapter 97*. London: HMSO, 1939
- 4.20 *Local Government Reorganisation (Miscellaneous Provisions) (No 4) Order*. London: HMSO, 1986 (SI 1986/452)
- 4.21 *Health and Safety at Work etc. Act 1974: Chapter 37*. London: HMSO, 1974
- 4.22 *Health and Safety: the Management of Health and Safety at Work Regulations 1999*. London: HMSO, 1999 (SI 1999/3242)
- 4.23 *Health and Safety at Work (Northern Ireland) Order*. London: HMSO, 1978 (SI 1978/1039)
- 4.24 *Management of Health and Safety at Work Regulations (Northern Ireland) 2000*. [s.l.]: The Stationery Office, 2000 (Statutory Rules of Northern Ireland 2000/388)
- 4.25 *The Reporting of Injuries, Diseases and Dangerous Occurrences Regulations 1995*. London: HMSO, 1995 (SI 1995/3163)
- 4.26 Rimington, J.D. Director General, HSE, letter to Dr J. W. Dougill, Chief Executive and Secretary, IStructE, 1 May 1995, Ref DG/97/95
- 4.27 *Health and Safety: the Construction (Design and Management) Regulations, 1994*. London: The Stationery Office, 1994 (SI 1994/3140)
- 4.28 Professional Lighting and Sound Association. *Application of the CDM Regulations to structures used in the television, film, theatre and entertainment industries*. (GN019-01). Available at <http://www.plasa.org/standards/guidance/GN019.pdf> (Accessed: 25 March 2007)

SECTION 5
PROCUREMENT AND USE

This Section is intended particularly for clients, venue owners, event organisers and designers

“The client should provide the contractor for the demountable structure with a written technical specification of requirements.”

“Last minute modifications cause many problems.”

“It is the client’s responsibility to provide temporary structures (and exits) that are safe for their users.”

“[Some of the] responsibilities of the client are to: make sure that competent persons are employed to design, erect, inspect and dismantle the structure; agree the expected nature and character of spectator activity at the event...”

5 PROCUREMENT AND USE

5.1 Procurement

5.1.1 General

The procurement of a demountable structure and its use should be an integral part of the planning, management and supervision of the event for which it is required^{5.1, 5.2}. It is the client's responsibility to provide temporary structures (and exits) that are safe for their users, including proper protection against the risks of fire and smoke.

A risk assessment, including a fire risk assessment, of the proposed event, and for the demountable structures erected for the event, should be made^{5.3}. The client should carry out the risk assessment for the event, while the contractor should undertake the risk assessment for all aspects of the provision of the structure. Once the structure has been handed over, responsibility for managing the structure will pass to the client.

In order to procure temporary demountable structures safely and efficiently, the principal responsibilities of the client are to:

- Make sure that competent persons are employed to design, erect, inspect and dismantle the structure.
- Agree the expected nature and character of spectator activity at the event.
- Provide the contractor with detailed information – see the checklist in Section 5.1.2.
- Recognise the need for the relevant enforcing authority approvals to be obtained in good time.
- Appoint a competent person to provide technical advice.
- Make sure that a safety plan is available.
- Appoint a safety coordinator (safety officer in the case of designated sports grounds), and security staff who are properly trained and briefed^{5.4, 5.5}.

Last minute modifications cause many problems. Such changes should be avoided, but where they are unavoidable modifications should be agreed by the contractor, the Enforcing Authority and the client or the client's agent. The modified design should be subject to a new independent design check, unless the changes are within the scope of the original design. The modification and basis for the agreement should be recorded.

5.1.2 Specification of requirements

The client should provide the contractor for the demountable structure with a written technical specification of requirements.

Information checklist

Information provided by the client may include, among other details, the following:

- Site of event and location of the demountable structure at the site.
- Type and details of event, e.g. sport, theatre, festival, conference, concert.
- Programme for supply of structure, e.g. date required, date by which structural calculations and drawings are required for comment, erection timescale, any limit to working hours.
- Type of structure required, e.g. grandstand, marquee, stage, (with/without roof).
- Size and weight of equipment to be supported by the stage and roof (where applicable).
- Accommodation needed on and in the structure, e.g. floor area, number of seats, sightlines, access to stage structure.
- Public access routes to site.
- Public evacuation times during the event.
- Access to site for erection and dismantling.
- Ground conditions, e.g. flat or uneven ground, hardstanding, soft ground.
- Enforcing Authority contacts (building control, environmental health and fire officers) to ascertain licensing and approvals requirements.
- Fire risk factors (see Section 3.5).

Management checklist

The following requirements will help to make sure that temporary demountable structures are procured and used efficiently and safely:

- Responsibility for design and erection of the structure and its foundations should rest with the contractor.
- Erection, and dismantling after use, should be carried out by people with suitable training and experience.
- Design calculations and drawings or a 'type approval' together with the independent design check should be submitted to the client or the client's agent.
- The structure should be designed by competent persons using accepted engineering principles and should comply with all relevant Standards and guidance documents, and with the specification requirements. Any variation should be subject to a further independent design check.
- Evidence of public liability insurance cover should be available from the contractor and from the event organiser.
- The structure and its foundations should

be protected from vehicular traffic, where necessary.

- After the structure has been erected it should be subject to a documented erection check by a competent person.
- The structure should be maintained fit for use at all appropriate times.
- The client should carry out or arrange for others to carry out periodic inspections and require the contractor or other competent person to undertake appropriate repairs and remedial works which may be necessary.

5.1.3 Compliance with regulations

It remains the client's responsibility to contact the Enforcing Authority to inform them of the proposals for a temporary structure, and to seek advice on responsibilities for enforcement, certificates, licences or permissions that are required, and any special local regulations that may apply. See Section 4 for further information.

Where the event is required to be licensed, the Enforcing Authority should check the calculations and drawings.

When applying for a licence for an event, the client should notify the Enforcing Authority which contractor(s) will be supplying the structures. The Enforcing Authority should then ask the client for the technical information they require. It is the client's responsibility to supply all technical information requested by the Enforcing Authority in good time before erection starts. Enforcing Authorities should raise any queries on the design sufficiently far ahead of the start of erection to give the contractor time to deal with any problems. This is a key requirement of any risk assessment and method statement.

Design documentation and technical information should be provided at least 14 days before erection starts, and the Enforcing Authority should respond in writing at least 7 days before erection starts. However, by their nature, temporary structures, such as tents and marquees, are often supplied at very short notice, particularly when weather conditions are very wet. It is not unusual for an enquiry to be made, an order placed, the tent or other structure erected, the event take place and the site cleared, all within less than a week.

The Enforcing Authority may also inspect the structure after, and possibly during, erection to verify that it is built in accordance with the

approved details, that it does not obstruct any exit route, and that, so far as is reasonably practicable, it does not lend itself to misuse by the public. Appraisal by the Enforcing Authority should not be used by contractors as a basis for reducing their own checking procedures.

Statutory requirements are discussed in more detail in Section 4.

5.1.4 Design and checking

Temporary structures, with the exception of small tents (see Section 12), whether proprietary systems intended for repetitive use or unique designs, should have calculations prepared for the structure, and the requirements for the foundations, by a competent person.

Requirements for providing information to Enforcing Authorities are discussed in Sections 4 and 5.1.3. Design calculations that have been subject to an independent check should be acceptable without further checking by each Enforcing Authority where the structure is used repetitively, provided that no changes are made to the structure. However, see Section 6.

A separate erection check of a demountable structure should also be carried out as discussed in Sections 5.3.5 and 7.

Design documents should be provided that cover the key aspects of the design, see Table 2 (page 31). If any of these documents are not applicable this should be clearly stated by the client/agent or designer as appropriate.

5.1.5 Equipment checking

Equipment should be checked by the contractor to make sure that it is fit for its purpose and fully meets any specification that has been laid down. For example, metal items with cracked welds, bent or buckled members, or steel items with large amounts of rust should be rejected.

All components should be examined during assembly and dismantling for signs of wear, deformation or other damage, and replaced if necessary. Correct alignment of components is important – they should not be bent, distorted or altered to force them to fit. Particular attention should be given to fastenings and connections. It is essential to provide suitable covering for bolts and fittings which project into or adjoin public areas (see Section 7.3).

5.2 Documents

5.2.1 Safety policies

Safety policies are documents drawn up to meet the legal requirements of Section 2 of the Health and Safety at Work, etc. Act 1974^{5.6}, and guidance on preparing them is available^{5.7, 5.8}. Section 3 of the 1974 Act provides duties in respect of ‘persons other than employees’. This legislation therefore deals with the safety of people using demountable structures, as distinct to the safety of workers involved in the erection.

5.2.2 Risk assessments and safety plans

This *Guide* recommends that risk assessments for a demountable structure, and to the risks that the structure creates by being at the site or venue, are carried out, as discussed in detail in Section 3.2. Confirmation that the risk assessment has been prepared should be given by the contractor in writing.

Safety plans should be used to assist in the management of hazards relating to the temporary structure at an event (see Section 3.6). They should generally be held by the safety coordinator for the event.

A proactive approach to planning is recommended to make sure that risks to safety are reduced to acceptable levels^{5.9, 5.10}. This may assist in reducing the risk of incurring liability from a claim under the Occupiers Liability Act 1957^{5.11} and from a claim alleging that the duty of care has been breached.

5.2.3 Method statements

Method statements should be drawn up for the erection, dismantling and removal of any structure by the contractor. They should be submitted to the Enforcing Authority with relevant drawings and structural calculations. The method statement should be specific to the structure.

5.2.4 Major incident plans

Large public assembly buildings and sites, such as football stadia, racing circuits and concert halls, should have contingency plans in place to ensure efficient management of dangerous incidents^{5.12}. The contingency plan should be prepared by the client. Emergency plans should be prepared by the emergency services to ensure an efficient strategic response to a major incident.

5.2.5 Fire certificates

Reference should be made to the Enforcing Authority or fire authority to determine the implications for the temporary structure.

5.2.6 Independent erection check and completion certificate

The client should make sure that a competent person has checked all structures after every erection and before use, to be certain that they conform to the relevant drawings and specified details. The client should verify that the checks have been carried out effectively and have been recorded on a form (the completion certificate) designed for this purpose by the contractor. As a minimum this should detail the type and location of the structure, the date of the inspection, the name and position of the competent person making the inspection, reference numbers or methods of identifying the design or erection drawings, and the nature of the inspection (physical, visual, etc.) obtainable from the Erection Check documents. This form should be handed, if necessary, to the client, who in turn should keep it for inspection by the Enforcing Authority.

Procedures for tents and marquees are described in Section 12.4. (See also the PTA Code of Practice^{5.13}).

If structural modifications are required after the completion certificate has been handed over, the following course of action should be followed.

- 1 A competent person should redesign the structure to take account of the modifications.
- 2 This should then be subjected to an independent design check.
- 3 An erection check should be carried out.
- 4 A new completion certificate should be prepared once the modifications have been made.

If structural modifications are required by an Enforcing Authority, written details of the changes required and the reasons for them shall be issued to the competent person who is to redesign the structure. The course of action detailed above shall be followed.

In all cases the structure should comply fully with the design criteria before users are admitted to it.

5.2.7 Document check list

Table 2 provides a checklist of documents that are applicable at the various stages of planning, designing and erecting temporary structures and the people usually responsible for preparing them. It should be noted that not all these items will apply in every case.

Table 2 Document checklist

✓	DOCUMENT	PREPARED BY	SECTION
CLIENT'S REQUIREMENTS			
	Statement of what the structure is required to do (the concept)	Client	5.1.2
	Statutory requirements, permissions and licenses	Client	4, 5.1.3
	Other technical requirements (including loading)	Client	5.1.2
SITE, LOCATION AND EVENT			
	Assumed or measured ground bearing capacity	Client	5.1.2, 6.2
	Statement of allowable loading for indoor floor on which temporary demountable structure is to be erected	Client	5.1.2
	Statement of required superimposed loading on temporary structure	Client	5.1.2
	Fire risk assessment for the event	Designer/Contractor	3.5, 4.8, 12.3
	Fire certificates	Client	5.2.5
	Safety plan	Client/Contractor	3.6
	Contingency plan	Client	5.2.4
DESIGN			
	Evidence of competence	Designer	5.1.1, 5.1.4
	Detailed design drawings, calculations and contact details and statement of what structure can do and any limitations	Designer	5.1.4
	Relevant information on standards and codes, and analysis or design software used in the design	Designer	5.1.4
	Design risk assessment	Designer	3.2
	Maximum leg load on foundations	Designer	5.1.4, 6.6
	Slope on which structure can safely be built	Designer	6.8
	For stages, ability of stage surface to meet given criteria	Designer	10.2.2
	Ability of the design to resist anticipated wind load	Designer	8.2, 8.3
	Ability of superstructure to support suspended equipment, including details of permissible support methods	Designer	10.2.2, 10.3.1
	Confirmation of independent design check	Contractor	5.1.4
ERECTION AND DISMANTLING			
	Evidence of competence	Contractor	5.1.2, 12.4
	Details of components to be checked at each erection	Contractor	5.1.5, 5.2.6, 7.1.2, 7.1.3, 7.3.3
	Records of inspection of structural components	Contractor	7.3
	Evidence that all lifting equipment is inspected and maintained in accordance with LOLER ^{5.14} , ^{5.15} .	Contractor	10.6
	Risk assessment(s) for erection and dismantling of structure	Contractor	5.2.2, 5.2.3
	Erection and dismantling method statements	Contractor	5.2.3
	Confirmation of independent erection check	Contractor	5.2.6, 7.1.2, 7.1.3, 12.4.2
USE			
	Details of methods for assessing windspeeds	Designer/Contractor	8.2, 8.3
	Details of action required at given windspeeds	Designer/Contractor	8.2, 8.3
	Completion certificate	Contractor	5.2.6, 12.4.2

5.3 Use

5.3.1 Supervision during the event

Good management is essential to provide proper safety for users of temporary demountable structures. Key aspects that should be considered in planning supervision during an event include the following:

- The safety coordinator should monitor the event and take action as necessary to make sure that demountable structures are used as planned and that safety is not compromised or jeopardized^{5.2, 5.3}.
- Users should not be admitted to a demountable structure until the safety coordinator is satisfied that it has been properly erected and complies fully with the design criteria.
- No structural members forming any part of a temporary demountable structure should be removed during use.
- The number and distribution of users for which a structure has been designed should not be exceeded.
- Sufficient stewards should be appointed by the client to each structure to safeguard spectators. They should be appropriately trained beforehand, be under the direction of a safety officer/coordinator and be briefed on safety and fire drills and their specific duties on the day^{5.4, 5.5}.

5.3.2 Access and egress

Consideration should be given to the access and egress arrangements, for a grandstand, tent or marquee, and around the site or building, and how these may affect people occupying the stand or tent, including provisions for people with disabilities^{5.1, 5.2, 5.16}. Fencing or other means should be adopted to prevent climbing of structures to gain unauthorised access. Access and egress for emergency vehicles should be discussed with the Enforcing Authority.

Unauthorised people should be kept away from under, on and around temporary structures, particularly to prevent tampering. The risk assessment for the structure should take this into account, and appropriate steps should be taken, which may range from notices prohibiting entry, to barriers, fencing or complete enclosure.

This *Guide* recommends that event organisers consider these aspects when deciding upon the geographical location of the structure and the arrangements for access and egress.

5.3.3 Electrical installations and lightning protection

Electrical installations in temporary structures should be adequately earthed in accordance with normal standards. Consideration should be given to the degree of exposure and likely risk of strike by lightning and, where appropriate, the structure itself should be adequately bonded or earthed^{5.17, 5.18, 5.19}. Advice on earthing and lightning protection should be sought from an electrical engineer.

Advice on lighting levels for normal and emergency use is available^{5.1, 5.2}.

5.3.4 Fire safety

This *Guide* does not attempt to provide comprehensive advice on fire precautions when temporary demountable structures are in use. Such information is well documented in legislation, codes of practice and advisory documents^{5.1, 5.3}. However, designers and contractors should appreciate modern approaches to fire technology and environmental psychology, as these may critically affect the design and use of demountable structures. A framework which may help in taking decisions on these aspects is given in Section 3.5.

5.3.5 In-service inspection and maintenance

Inspection and maintenance procedures need to be properly determined, specified and understood by the client and contractor, as discussed in Sections 7.1.3 and 7.3. The client should make sure that a competent person inspects a demountable structure before use, to check that it is in a sound condition or to arrange for any remedial work needed. Some demountable structures remain in use for considerable lengths of time and particular care may be needed over their long-term condition: requirements that may apply to permanent structures should be considered.

The structure should be inspected regularly by a competent person to ascertain whether any significant movement or differential settlement has occurred. If significant movement is evident, a report should be submitted immediately to the client and or contractor as appropriate and remedial work will be required. This may involve repacking and levelling or installing another type of foundation. The contractor should check that the structure has sufficient redundancy to allow remedial work to proceed without endangering overall stability (see also Section 6.10).

Operational management of structures for wind is discussed in Section 8.2 for grandstands, stages and other structures, and in Section 8.3 for tents and marquees.

If heavy rain or flooding occurs, the loadbearing capacity of the ground may be reduced, guy ropes may slacken, and anchorages may be loosened. In strong winds, guy ropes may need regular tightening and anchorages may need to be checked for movement.

Minor damage to the structure may occur while it is in service. Provided such damage does not endanger public safety, the damaged components should be clearly marked so they can easily be identified during dismantling and set aside for repair or rejection.

5.4 References

Readers are advised to check for updates given to references throughout this document.

- 5.1 Department of National Heritage and Scottish Office. *Guide to safety at sports grounds*. 4th ed. London: The Stationery Office, 1997
- 5.2 Health and Safety Executive. *The event safety guide: guide to health, safety and welfare at music and similar events*. London: HSE, 1999 (HSG 195)
- 5.3 *Health and Safety: the Management of Health and Safety at Work Regulations 1999*. London: The Stationery Office, 1992 (SI 1999/3242)
- 5.4 *Private Security Industry Act 2001. Chapter 12*. London: HMSO, 2001
- 5.5 Security Industry Authority. Website at: <http://www.the-sia.org.uk> (Accessed: 19 February 2007)
- 5.6 *Health and Safety at Work etc. Act 1974: Chapter 37*. London: HMSO, 1974
- 5.7 Football Licensing Authority. *Guidance notes for drawing up a statement of safety policy for spectators at football grounds*. Available at: <http://www.flaweb.org.uk/docs/specsafe/pubs/safety.php> (Accessed: 19 February 2007)
- 5.8 Health and Safety Executive. *Health and safety regulation: a short guide*. Sudbury: HSE Books, 2003 (HSC 13 REV1)
- 5.9 Health and Safety Executive. *Five steps to risk assessment*. Sudbury: HSE Books, 2006 (INDG 163 REV2)
- 5.10 Health and Safety Executive. *Successful health and safety management*. Sudbury: HSE Books, 1997 (HSG 65)
- 5.11 *Occupiers' Liability Act 1957: Chapter 31*. London: The Stationery Office, 1957
- 5.12 Football Licensing Authority. *Contingency planning*. Available at: <http://www.flaweb.org.uk/docs/specsafe/pubs/cplan.php> (Accessed: 19 February 2007)
- 5.13 Made-Up Textiles Association. *A code of practice for marquee hiring contractors and code of public safety: use and operation of marquees*. Tamworth: MUTA, 2001
- 5.14 *The Lifting Operations and Lifting Equipment Regulations 1998*. London: HMSO, 1998 (SI 1998/2307)
- 5.15 Health and Safety Commission. *Safe use of lifting equipment. Lifting operations and lifting equipment regulations 1998: approved code of practice and guidance*. Sudbury: HSE Books, 1998 (L113)
- 5.16 Murray, C. *Designing for spectators with disabilities: with guidance on the revised Building Regulations*. London: Football Stadia Advisory Design Council, 1992
- 5.17 *BS EN 62305: Protection against lightning*. London: BSI, 2006 [4 parts]
- 5.18 *BS 7430: 1998: Code of practice for earthing*. London: BSI, 1998
- 5.19 *BS 7909: 1998: Code of practice for design and installation of temporary distribution systems delivering a.c. electrical supplies for lighting, technical services and other entertainment related purposes*. London: BSI, 1998

SECTION 6
GROUND AND SITE CONDITIONS

This Section is intended particularly for designers, contractors and suppliers of demountable structures

“Designers and local authorities should be aware that the performance of the ground under short-term loading can be significantly different from that when the loading is applied for a long period.”

“Clients should give basic information on ground conditions including contamination but it is likely that a competent person will be required to determine the allowable bearing capacity on which demountable structures are founded. Local knowledge is invaluable.”

6 GROUND AND SITE CONDITIONS

6.1 Introduction

Demountable structures are used in a wide variety of situations both outside and indoors. Loadings should be distributed so that any bearing pressures and differential settlement are within acceptable limits.

Designers and local authorities should be aware that the performance of the ground under short-term loading can be significantly different from that when the loading is applied for a long period. Long-term settlement and associated differential settlement are often less significant for temporary structures than for permanent structures. Therefore, the allowable bearing pressures on a given type of ground for temporary demountable structures may be different from those associated with permanent buildings. The risk assessment for the structure should take this into account.

6.2 Information

Clients should give basic information on ground conditions including contamination but it is likely that a competent person will be required to determine the allowable bearing capacity on which demountable structures are founded. Local knowledge is invaluable. Geotechnical information collected for other structures on the site is a good source of foundation design data and may include desk study information for the particular location.

The client should notify the contractor of the position of underground services or overhead cables which may present hazards during the erection or use

of the structure. If underground services or overhead cables cross the site where the structure is to be erected, the client should first obtain advice from the service company concerned.

Further information is available in DIN 1054^{6.1}.

6.3 Basic principles

BS 8004, the Code of Practice for Foundations^{6.2}, gives recommendations for ‘the normal range of building and civil engineering structures’; it does not specifically relate to temporary demountable structures. However, BS 8004 may be used as a starting point to assess allowable bearing pressures bearing in mind the comments made in Section 6.1 above.

Structures should be supported on foundations of such a size that the bearing pressures do not exceed allowable values. Temporary demountable structures often use steel uprights (RHS/CHS/UB or UC Columns or scaffold tubes) fitted with steel baseplates. These often sit onto timber spreaders e.g short lengths of scaffold board or railway sleepers. The point loads from the structure should not exceed the allowable loads on the steel baseplates, particularly when these have small plan dimensions. Likewise the baseplate loads should not cause local crushing of the timber spreaders. Wet/rotten timber is much more prone to crushing and such items should be rejected and replaced.

Some large structures, such as multi-storey ‘Hospitality Box’ buildings, generate high stanchion loads. In these cases a grillage of suitable spreaders (e.g railway sleepers) is needed to adequately spread the load to the supporting ground. In cases where repeat use of the structure is likely then it can be an advantage to provide permanent concrete pads with holding down bolts housed within covered manholes (Figure 5).

The greatest risk of foundation failure is of soft spots due to peat, unconsolidated fill, cavities, land drains, previous excavations, etc. These may not be apparent at the surface but may be detected by probing, trial pits or small-scale excavation. In all such operations the danger posed by underground services should be assessed and acted on accordingly.

Unequal settlement could set up high stresses and deformations in the structure. The position of the supports should therefore be set out on site and any soft spots which coincide with the support positions should be excavated and replaced with compacted granular fill or bridged with grillages or other suitable transfer structures.

It should be noted that tower structures are particularly sensitive to differential settlements which may cause tilting of the structure.



Figure 5 Permanent base for regular re-use

6.4 Ground bearing pressures

The allowable bearing pressure on the ground is the pressure that can be safely applied to the ground. It involves recognising both ultimate (collapse) and serviceability (movement) limit states.

Demountable structures for outdoor applications are generally loaded for relatively short periods. Whilst it is well known that settlement usually comprises both immediate and longer-term movements, the latter may not need to be taken into account unless the structure will be in use for more than 28 days, in which case a full engineering assessment of the ground should be made.

The ground surface on which temporary structures are positioned may include asphalt or gravel paths, pasture, heaths, sports fields, concrete or bituminous surfaced areas, hardstandings and the like. Before they are accepted for carrying the design loads, the suitability of such surfaces should be visually checked by a competent person, augmented as necessary by a desk study, by excavating trial pits, or by ground investigation involving soil tests or load tests, and taking account of local knowledge.

Particular care should be taken where structures are supported on bituminous, concrete or similar hardstandings. It should be recognised that the thickness of the surface and the thickness and type of the underlying material are critical to the ability of the surface to support load.

When making any assessment, consideration should be given to existing and possible future weather effects. For example, frozen or dried-out ground will support higher pressures than the same ground when it has thawed or become wetted by heavy rain.

In no case should overall allowable bearing pressures exceed the values given in Table 3 unless this has been justified by site testing. If test data are not available or if there is doubt about the uniformity of the site conditions, the pressures in Table 3 may need to be reviewed and possibly adjusted by a competent person. In the absence of reliable local or professional engineering knowledge, an allowable bearing pressure not exceeding 50kN/m² should be assumed.

Made ground, especially granular materials, can support vertical loads but its heterogeneous nature requires careful judgement by a competent person to assess its bearing capacities. Peat and organic subsoils, (i.e. a depth of topsoil greater than that usually associated with normal grassed areas) are unsuitable for bearing surfaces under any circumstances. Regularly spaced and equally loaded timber spreaders may be safely supported on grassed areas such as lawns, heaths, fields, playing fields, etc provided that the

Table 3 Indicative values of allowable bearing pressures for foundations of structures in place for less than 28 days

Bearing material ^a	Allowable bearing pressure (kN/m ²)
Dense sand	200
Medium dense sand	150
Loose sand	75
Stiff clays	150
Firm clays	75
Note	
^a This is the material immediately below the superficial layers of topsoil, hardcore or fill, etc.	

topsoil/grass is not greater than 200-250mm thick and that the ground is dry and stable and not subject to excessive softening if wetted.

6.5 Foundations

The designer should specify the foundation loads on the erection drawings, including any uplift forces and lateral loads, and should show typical methods of transferring the loads to the ground. As well as ensuring that allowable bearing pressures are not exceeded, adequate resistance to sliding and uplift should be provided.

A minimum factor of safety of 1.5 should be applied, i.e. where $1.5 \times$ overturning moment exceeds $1.0 \times$ restoring moment, a fixing to the ground should be provided using ground anchors or kentledge provided at the support points.

Occasionally, ground anchors cannot be used because of the nature of the ground. For example, it may not be permissible to puncture asphalt or concrete finishes. The structure should then be designed to accept kentledge of sufficient weight to resist the factored uplift forces.

Adjacent foundations should be positioned far enough apart to avoid interaction between them.

No supports should be founded on ground that has been excavated locally unless the backfill is properly compacted granular material.

In some instances, especially if the temporary structure is to be supplied to the same site on a regular basis, it may be advisable to install permanent foundations: these will normally be concrete pads, strips or slabs, but in practice any form of foundation could be considered, e.g. short bored piles.

If permanent foundations in the form of concrete pads are provided, they should be founded at a depth below the superficial layers where frost and shrinkage will not be problematic.

6.6 Soleplates, baseplates and spreaders

In this context soleplates will be considered to be small steel plates normally 150mm–200mm square typically associated with scaffolding systems, baseplates (Figure 6) are heavier steel plates fixed to more substantial column sections, and spreaders will be timber plates or baulks placed between the steel plates and the supporting ground.

The normal method of support for temporary demountable structures is to place timber spreaders on the ground then to use scaffolding screw jacks with soleplates to level up the structure. Special heavy-duty baseplates are sometimes used for temporary demountable structures; these are larger, stiffer and stronger than conventional scaffold soleplates. They are usually associated with hospitality box structures and the like where conventional structural sections are used as the main load bearing columns.

In certain circumstances timber spreaders are not required, however this can only be where good quality concrete, asphalt or other known surfacing can be relied on to safely support relatively light loadings. It should be noted that many tent and marquee designs do not require timber spreaders as the downwards leg loads are small compared to uplift forces, the uplift forces needing to be resisted by suitable kentledge or ground anchors (see Figures 6 and 7).

Experience has shown that timber spreaders may be placed directly onto grassed surfaces underlain by ground of adequate bearing capacity. However, wherever structures are placed on grassed slopes the turf/topsoil should be excavated locally to provide horizontal bearing beneath the spreader.

Section 6.5 notes that foundations should be positioned so as to avoid interference between them. This factor, coupled with practical experience over

many years, suggests that localised point loads on top soil can exceed the values given in Table 3. DIN 10546.1 suggests that this effect is due to the conical distribution of applied vertical forces through localised areas of topsoil. Conservative values that have been found to be satisfactory are presented in Table 4.

Baseplates and spreaders should be engineered and their size and distribution not left to chance. Design calculations should be prepared to show how the leg loads are transferred to the ground. Experience has shown that the use of either scaffold planks or railway sleeper spreaders are generally satisfactory.

Concentrated soleplate/baseplate loads should be assumed to spread through the timber spreader at 2 horizontal to 1 vertical along the grain, and 1 to 1 across the grain unless proven otherwise by calculation. For heavy leg loads the provision of a grillage of spreader timbers may be necessary.

Soleplates and baseplates should be inspected by the contractor to check for damage before each use. They should be positioned centrally under the load unless indicated otherwise in the design documentation. Failure to comply with this requirement may result in bearing stresses far in excess of calculated values, leading to local overstress of the ground and unacceptable differential settlement of the structure.

Table 4 Indicative values of vertical loads on adequate baseplates for different bearing materials for structures in place for less than 28 days

Bearing material	Allowable load (kN)	
	150 × 150mm	250 × 250mm
Dense sand	9	27
Medium dense sand	6	18
Loose sand	2	6
Stiff clays	5	15
Firm clays	2.5	7.5



Figure 6 Frame marquee base plate

6.7 Ground anchors

Several types of proprietary ground anchor are available (see Figures 6 and 7). Manufacturers of ground anchors usually provide data on safe working loads for various soil types. It should be noted that these allowable loads vary considerably. Ground anchors should be designed by a competent person and installed in accordance with the manufacturers' guidelines and recommendations.

Ground anchors can be difficult to install accurately. This can lead to eccentricities which will give rise to bending moments in the structure or in the foundations which need to be accounted for in the design.

Given the variability of the effectiveness of ground anchors in different soils, confidence in their capacity can be provided by testing, for instance by means of a fork lift truck with a calibrated load cell. Such testing should be in the direction of the force to be resisted by the ground anchor. A suitable factor of safety should be applied to the ultimate failure load using this method in order to determine the allowable tensile load.

The Health and Safety Executive has undertaken research into factors affecting the load carrying capacity of ground anchors used to support temporary structures^{6.3}.

6.8 Sloping ground

If a site slopes or is uneven, the ground should be able to be made flat or the structure should be capable of being modified to deal with the unevenness (see Figure 8). Where the ground is not level or near level and the foundation bases for the structure cannot be set at an angle, a level base should be provided. This may be done either by cutting steps into the ground or by laying timber sleepers up the slope with timber blocks, shaped to match the slope, fixed to the sleepers to form individual foundations for each upright.

It should be noted that the bearing capacity of foundations on a step will reduce, depending on the slope of the surrounding ground. This reduction should be allowed for in design. The stability of the sloping ground should be checked by a competent person.

Care is required to obtain full and even contact with the ground. Depressions should be filled and loose material compacted. If the ground is uneven and significant packing is used, care should be taken that stability is maintained.

Where a site slopes or to raise a viewing platform, scaffolding substructures, supporting the

main structure, are often provided. The requirements for spreaders and or grillages etc. described previously are equally relevant to the substructure but the interface between it and the main structure above should be considered. It is essential that the designs of the two elements are fully co-ordinated so that the correct load paths (vertical down loads, uplifts and lateral loads) can be maintained and the necessary connections made. It is important that one competent person has overall responsibility for co-ordinating the various designs.



Figure 7 Ground anchors

6.9 Site drainage

Where possible, the site of the temporary demountable structure should be chosen so that it is not liable to flooding as this could either reduce the loadbearing capacity of the ground or wash away the ground under the supports. Where possible, the site chosen for the structure should not be in an area where water could soften or erode the ground or cause scouring. If this cannot be avoided, a suitably hard foundation should be prepared that is deep and wide enough to prevent it being undermined during the time the structure is erected.

Particular care should be taken when positioning rainwater pipes from roof structures. They should, if possible, discharge well away from the main structural supports.

6.10 Inspection

After the structure has been erected, both it and the ground should be checked regularly to ascertain whether any significant movement, displacement or differential settlement has occurred. A reduction in loadbearing capacity or overloading could cause excessive settlement. Overloading could occur if the rigidity of the temporary structure prevents some

of the spreaders from bearing on the soil, leaving the structure to span between supports that are not adjacent to each other. If significant movement is evident, remedial work will be required. This may involve repacking and levelling, or installing another type of foundation. The contractor doing the repacking or levelling should check that the structure has sufficient redundancy (alternate load paths capable of carrying structure loadings safely to the ground) to allow remedial work to proceed without endangering overall stability.

6.11 References

- 6.1 *DIN 1054:2005-01 Baugrund – Sicherheitsnachweise im Erd- und Grundbau [Building ground – verification of the safety of earthworks and foundations]*. Berlin: DIN, 2006
- 6.2 *BS 8004: 1986: Code of practice for foundations*. London: BSI, 1986
- 6.3 Health and Safety Laboratory. *Factors affecting the load carrying capacity of ground anchors used to support temporary structures*. Sheffield: HSL, 1998 (ME/98/02)



Figure 8 A structure on sloping ground

SECTION 7
ERECTION, INSPECTION AND DISMANTLING

This Section is intended particularly for contractors and suppliers of demountable structures and for those who supervise and inspect sitework

“The critical erection stages for temporary demountable structures should be identified during the design process. To ensure adequate provision against overturning during erection, temporary strutting and/or guying may be necessary. Such requirements should be adequately communicated to the site operatives. An Erection Method Statement, together with drawings, is recommended for this purpose.”

“The structure should be erected safely in accordance with the Erection Method Statement and drawings provided.”

“Bracing should be arranged to provide stability at all stages of erection.”

“Inspection is essential to maintain the safety and integrity of a demountable structure.”

“Damaged or defective components should be clearly marked and removed from the site as soon as possible.”

“The repeated use of demountable structures will inevitably lead to general wear and tear in addition to damage or distortion that may occur during handling, transportation, assembly and dismantling.”

7 ERECTION, INSPECTION AND DISMANTLING

7.1 Erection

This Section provides guidance on temporary structures other than tents and marquees, for which reference should be made to Section 12.

7.1.1 Planning

The critical erection stages for temporary demountable structures should be identified during the design process. To ensure adequate provision against overturning during erection, temporary strutting and/or guying may be necessary. Such requirements should be adequately communicated to the site operatives. An Erection Method Statement, together with drawings, is recommended for this purpose (see Section 5.2.3).

The drawings should be detailed enough to enable the main structural components, including connectors, to be identified and scheduled for delivery to the site. All components should be marked for ease of identification wherever possible (by such means as tags, paint marking or stamping) and in a manner that would not be detrimental to the performance of the component. Deliveries should be organised to allow the erection to proceed in the planned erection sequence. Wherever possible, the drawings should also identify the site location.

The tolerances of assembly should be specified by the designer. Particular care should be taken to minimise eccentricities at structural joints. Diagonal bracing is often a problem in this respect. Care should be taken in design to ensure that theoretical force lines take account of the size and bulkiness of connectors and couplers.

7.1.2 Work on site *Erection of structure*

The structure should be erected safely in accordance with the Erection Method Statement and drawings provided.

All kentledge, temporary guying and other means of temporary support identified in the Method Statement should be properly installed to provide for the safety of operatives.

All work at height must be fully assessed and carried out in compliance with the requirements of the Working at Height Regulations 2005^{7.1}.

Care should be taken to use the correct component in the correct location and orientation. All components should be carefully aligned. They should not be bent, distorted, or otherwise altered to force a fit. Particular

attention should be paid to tightness of connections. The torque applied to bolts and other connectors should be in accordance with the manufacturer's recommendations.

Care should be taken to ensure that all ties and bracings specified have been correctly installed.

Site alterations or adaptations to the specified design should not be made without verification by the designer.

Substructures

Modular Grandstands

Where designs rely on horizontal frictional resistance between baseplate and ground, care should be taken to ensure that the assumptions in the design are met in the installed detail.

These types of structure can be susceptible to dynamic loading. Where it is expected that crowd-induced dynamic loading may occur it is recommended that horizontal ties should be introduced over the full width of the base of the structure rather than relying on frictional resistance.

Scaffold structures

Where a scaffold (tube and fitting) substructure is required to overcome rough terrain or in other circumstances, its erection should be carried out in accordance with standards of workmanship given in BS EN 12811-1:2003^{7.2}, BS 5975^{7.3} and the appropriate NASC guidance^{7.4} but with the following modified tolerances of assembly:

- Verticals should be plumb within 8mm over 2m of height, subject to a maximum displacement from the vertical of 25mm over the full height of the structure.
- Verticals should not rise above the upper lacing members or extend below the lowest lacing member by more than 300mm.
- Tubes should have joints in adjacent members staggered, and such joints should be made with sleeve couplers or other suitable means in compression members; splicing may be required where high tensile loads are being developed; the centrelines of tubes at node points should be as close together as possible, and not more than 200mm apart.
- Soleplates should be set horizontal within a tolerance not exceeding 15mm in a length of 500mm. Alternatively, soleplates can be laid on a slope with the standards either having a swivel foot or a block built onto the inclined soleplate to give a level base. In these cases, the soleplate will

need to be laid against a stop to prevent it sliding down the slope.

- Members supporting the demountable structure should be level to within 15mm in 3m, subject to a maximum total deviation of 50mm.

Putlog couplers (which are intended as positioning devices), wrap-overs, fence couplers and similar items should not be used for structural connections.

It is important to recognise the need for meeting the tolerances noted, since it is through poor erection of these structures that several collapses have occurred.

For modular structures, and system scaffolds, manufacturers' recommendations for tolerances of assembly should be followed, if more onerous.

Bracings and connections

All necessary bracings and other components should be incorporated as assembly progresses (Figures 9 and 10). Bracing should be arranged to provide stability at all stages of erection. A check should be carried out to see that the necessary connections are made and that linking components are not strained to achieve engagement. Local instability that might endanger the complete structure when loading occurs could arise through omitting or failing to tighten a bolt. Constant emphasis should be placed on the importance of paying attention to detail.

Safety of operatives

It is recommended that guidance for the safety of operatives involved in construction work should be followed^{7.5}. PPE, including fall arrest equipment^{7.6} should be used where appropriate. Suitable anchorage points should be identified in the design.

Inspection of structures

Inspection is essential to maintain the safety and integrity of a demountable structure. Inspections are required at various stages and these will mainly be the responsibility of the contractor. The client, the safety coordinator and local authority may also make inspections.

During erection, the contractor should make regular inspections to verify the design assumptions and to check that work is being carried out in accordance with the documentation provided. The initial inspection should concentrate on setting out and site preparation. Subsequent inspections should check the orientation and location of the components, especially bracing members, the use of temporary supports and the proper installation of the correct connectors, couplers and fittings.



Figure 9 Detail of a lightweight substructure for a grandstand



Figure 10 A heavy duty substructure arrangement

All inspection work should be recorded. Specific reference should be made to remedial measures that have been identified and to dates agreed for carrying out such work.

The client should be provided with a full set of erection documentation. Key stages of erection should be highlighted to show where particular safety measures should be taken. The client's safety coordinator should be invited by the contractor to examine the structure at any stage during erection and subsequent use.

The contractor should carry out any remedial work deemed necessary as a result of these inspections unless the contractor can provide documentary evidence to show that the as-built situation is safe.

Local authority

Where a local authority licence is required, the local authority inspector should be provided with a full set of documents for the assembly of the temporary structure and may inspect it at any stage. Particular attention will be paid to site preparation and the fully assembled structure. The inspector may require copies of any documents which formalise earlier inspections.

7.1.3 Erection check

The PTA Code of Practice^{7.7}, while written particularly for tents and marquees, provides a useful framework for planning inspections of some other types of temporary structure. Figure 11 shows an example of a scaffold substructure for a temporary structure.

After erection, the structure should be subject to an erection check by a competent person.

The inspection should be followed by a systematic local check of the complete structure. A drawing and checklist should be available for continuous reference. The inspection should check that:

- Setting out is accurate within the tolerance required.
- The foundations are adequate, that they are not likely to be disturbed and that they and the lower portion of the supporting structure are not liable to damage by interference, accident, traffic, scour, undermining, or any other cause.
- Suitable soleplates have been provided, properly levelled and, where necessary, adequately supported. The soleplates have been properly bedded down, with no unacceptable settlement.
- Members are correctly positioned and connected.



Figure 11 A large substructure arrangement for a concert in Tel Aviv, Israel

- The stipulated limits of extension of adjustable components have not been exceeded.
- All required components, pins, bolts, nuts, clips, etc. are of the correct type, have been correctly inserted and are secure.
- Decking, seating and guardrails have been correctly installed and are secure.
- Services to the structure do not in themselves create a hazard or impose loadings not catered for in the design.
- Where a contractor employs scaffold tubes and fittings within a structure, an agreement is in place between the contractor and the client on the extent of the random check to be made on the scaffold fittings. The number of fittings to be tested, the test requirements, the written record that should be made and the percentage that may fail should all be agreed, and any fittings that fail should be replaced.

The inspection should check that the actual erection conforms to the design documents supplied by the contractor. Any deviations should be substantiated and supported by additional documentary evidence. The results of the inspection should be recorded in writing and action taken to correct any faults. On completion of a satisfactory inspection the client should be informed and confirmation made in writing.

After the structure is completed and inspected, it should be secured to prevent vandalism. Unauthorised access beneath temporary structures should not be permitted.

It is recommended that a competent person should inspect each structure while it is in use, the frequency of the inspection depending on the nature of the event. If a structure remains in use for a period of time (for example, for a series of concerts at a festival), it should be inspected before each use.

7.2 Dismantling

The dismantling of a demountable structure is important since its components are likely to be reused. Care should be taken to maintain the safety of the dismantling team and other people nearby. All work at height must be fully assessed and carried out in compliance with the requirements of the Working at Height Regulations 2005^{7.1}.

The critical erection stages should have been identified during design. The safest dismantling plan will normally be to reverse the erection procedure. Any temporary guying used to erect

the structure will therefore be required when dismantling. This should prevent components from being bent, distorted or overstressed during dismantling. Minor damage to the structure may have occurred whilst in service and the damaged components should have been clearly marked for ease of identification when dismantling. During dismantling, the contractor should examine all components for signs of wear, deformation or other damage. Damaged components, or those with temporary repairs, should be set to one side for rejection or permanent repair off site.

7.3 Inspection of components

7.3.1 Repeated use of components

The repeated use of demountable structures will inevitably lead to general wear and tear in addition to damage or distortion that may occur during handling, transportation, assembly and dismantling. The contractor should regularly inspect all components for use in a demountable structure – erection aids as well as components in the structure itself – for signs of wear, deformation or other damage, following the procedures set out in Section 7.3.3:

- When allocated at the stockyard.
- On arrival at site or during unloading.
- During assembly.
- Whilst in service.
- During dismantling.
- On arrival back at the stockyard.

Since components may be reused many times, particular attention should be given to identifying damaged or corroded components; any components whose structural efficiency has been or could be impaired should be rejected. Damage or deterioration may be corrected, if practicable, but if repair is not practical or economic, the component should be replaced. Damaged or defective components should be clearly marked and removed from the site as soon as possible.

Spare components should be readily available to allow necessary repairs to be undertaken rapidly. Temporary repairs using makeshift components should be avoided.

Typically damage can include:

- Tube and prefabricated components: corrosion, cracking, deformation, creasing, split ends, non-flat or non-square ends, weld integrity.
- Connectors, couplers, fittings: deformation, distortion, damaged threads.

7.3.2 Scaffolding components

Steel scaffold tube that is corroded to the extent of rust flaking or severe pitting of the surface should be cleaned of all loose material. It should then be measured for external diameter and checked against the minimum requirements of BS EN 39:2001^{7.8}. Particular attention should be paid to the 75mm length at the tube ends as this tends to corrode more than the remainder of the tube.

Tube should be free from cracks, and should have the ends cut square, smooth and free from burrs. Sections of tube that have been partly sawn, seriously deformed or creased by abuse should be cut out and scrapped. Tubes that have become thin or split at the ends should be shortened by an appropriate amount. Bent tubes should be straightened so that they do not deviate more than 5mm from a straight line in any 2m length.

Fittings should be inspected. They should not be used if they are damaged in such a way that their efficiency is reduced. It is necessary to check that threads are not damaged. Any damage should be corrected by repair, or replacement, but if this is not possible, the item should be secured against reissue.

Baseplates should be checked for the integrity of the welds, the squareness of the base to the stem, and flatness of the plate.

Prefabricated components should be checked for damage, distortion and weld integrity. Faulty or suspect items should be repaired, checked dimensionally and, if necessary, offered to jigs in order to achieve acceptable fits on future use.

In order to minimise deterioration and accidental damage, all elements should be carefully stored to prevent distortion and protected to an appropriate extent against deterioration.

7.3.3 Inspection of structural components used repetitively

This Section sets out minimum required inspection routines and guidelines for the user and/or owner. It is intended for guidance only and covers components such as those used in the construction of stages and ancillary structures. Users and owners should seek advice about specific inspection routines from the manufacturer or a competent person.

The guidelines are based on ANSI E1.27⁹, ANSI E1.217¹⁰, BS 7905^{7.11}, 7.12 and BS 7906^{7.13}, 7.14.

There are two types of inspections: frequent inspections and periodic inspections, which should be carried out following the procedures set out in Table 5. Structures in regular service should be subjected to both frequent and periodic inspections as described below.

Frequent inspections are visual inspections for which records are not required to be kept. Structural components not in use for a period of one month or more should be subject to a frequent inspection.

Periodic inspections are visual inspections for which records are required to be kept. When purchased or acquired, whether new from the manufacturer or used, all structural components should be inspected in accordance with the periodic inspection procedures. Such action should establish the basis for the record keeping requirements.

Structural elements not in service for a period of one year or more should be subject to a periodic inspection. Periodic inspections should be carried out on all structural components that are permanently installed (i.e. for more than 28 days) in a stationary and non-movable configuration, and the frequency of inspection should be based on the prevailing exposure conditions.

Periodic inspections should be carried out every three months on all structural components that are installed in a permanent configuration where movement of the structural system is an integral part of its use.

Records for each structural component should be kept on file and should be signed and dated by the person conducting the inspection.

If a structural component shows significant visible damage or is suspected of containing a damaged element, whether visible or not, it should be removed from service and marked accordingly. A competent person should perform an assessment. Any damaged structural component that is deemed un-repairable should be permanently removed from use or service, and should be permanently marked in a manner that clearly and visibly indicates their condition.

Repairs should only be made by a competent person.

Table 5 Inspection procedures for structures that are used repetitively		
Items for inspection	Frequent inspection procedure	Periodic inspection procedures
	Frequent inspections should be performed by a competent person, and should be conducted prior to each use and after any incident	Periodic inspections should be performed by a competent person and should be conducted at least once each year. All structural elements should be taken out of service during inspection
	Inspect item for:	Inspect item for:
Main members	<ul style="list-style-type: none"> • Denting • Bends • Abrasion 	<ul style="list-style-type: none"> • Denting • Bends • Abrasion
Secondary members	<ul style="list-style-type: none"> • Denting • Bends • Abrasion • Missing members or connectors 	<ul style="list-style-type: none"> • Denting • Bends • Abrasion • Missing members or connectors
Connecting plates	<ul style="list-style-type: none"> • Flatness • Deformation or excessive wear of holes 	<ul style="list-style-type: none"> • Flatness • Deformation or excessive wear of holes • Corrosion
Pinned connectors	<ul style="list-style-type: none"> • Deformation 	<ul style="list-style-type: none"> • Excessive abrasion • Deformation of connection pin holes • Method of connection
Welds	<ul style="list-style-type: none"> • Cracks and abrasion 	<ul style="list-style-type: none"> • Cracks by visual inspection - 100% all welds • Abrasion by visual inspection - 100% all welds • A competent person should undertake dye penetrant testing on any weld that is thought to be or may be defective.
Fasteners (proprietary 1/4 turn fasteners, bolts, pins)	<ul style="list-style-type: none"> • Proper grading – must be matched • Deformation • Excessive wear 	<ul style="list-style-type: none"> • Proper grade of fasteners – must be matched • No deformation of fasteners • Excessive wear
Geometry of structural element	<ul style="list-style-type: none"> • Twisting of structural element • Squareness of structural element • Bending of structural element 	<ul style="list-style-type: none"> • Twisting of structural element • Squareness of structural element • Bending of structural element • Sweep • Camber

7.4 References

Readers are advised to check for updates given to references throughout this document.

- 7.1 *The Work at Height Regulations 2005*. London: The Stationery Office, 2005 (SI 2005/735)
- 7.2 *BS EN 12811-1: 2003: Temporary works equipment. Scaffolds. Performance requirements and general design*. London: BSI, 2004
- 7.3 *BS 5975: 1996: Code of practice for falsework*. London: BSI, 1996
- 7.4 National Access and Scaffolding Confederation. *Technical guidance notes*. [various]
- 7.5 British Constructional Steelwork Association. *BCSA code of practice for low rise buildings*. London: BCSA, 2004 (BCSA publication 36/04)
- 7.6 *BS 8437: 2005: Code of practice for selection, use and maintenance of personal fall protection systems and equipment for use in the workplace*. London: BSI, 2005
- 7.7 Made-Up Textile Association. *A code of practice for marquee hiring contractors and code of public safety: use and operation of marquees*. Tamworth: MUTA, 2001
- 7.8 *BS EN 39: 2001: Loose steel tubes for tube and coupler scaffolds. Technical delivery conditions*. London: BSI, 2001
- 7.9 *ANSI E1.2-2006: Entertainment technology: design, manufacture and use of aluminum trusses and towers*. New York: ANSI, 2006
- 7.10 *ANSI E1.21-2006 Entertainment technology: temporary ground-supported overhead structures used to cover the stage areas and support equipment in the production of outdoor equipment in the production of outdoor entertainment events*. New York: ANSI, 2006
- 7.11 *BS 7905-1: 2001: Lifting equipment for performance, broadcast and similar applications. Specification for the design and manufacture of above stage equipment (excluding trusses and towers)*. London: BSI, 2001
- 7.12 *BS 7905-2: 2000: Lifting equipment for performance, broadcast and similar applications. Specification for design and manufacture of aluminium and steel trusses and towers*. London: BSI, 2000
- 7.13 *BS 7906-1: 2005: Use of lifting equipment for performance, broadcast and similar applications. Code of practice for installation, use and removal of above stage equipment (excluding trusses and towers)*. London: BSI, 2005
- 7.14 *BS 7906-2: 2000: Lifting equipment for performance, broadcast and similar applications. Code of practice for use of aluminium and steel trusses and towers*. London: BSI, 2000

SECTION 8 WIND LOADING

This Section is intended particularly for designers, contractors and suppliers of demountable structures, and for those monitoring temporary structures during use

“The design documents should clearly state the maximum gust wind speed at which the structure remains stable.”

“Frequent reference should be made to local weather forecasting services to determine the level of active safety management and the size of the crew.”

8 WIND LOADING

8.1 Introduction

8.1.1 General

The first part of this Section gives guidance on design and operational management of temporary demountable grandstands, stages and ancillary structures to resist wind loads. Design and management of tents and marquees for wind are then discussed in Section 8.3.

The design documents should clearly state the maximum gust wind speed at which the structure remains stable.

8.1.2 Basic principles

All structures must be designed to safely resist the loading (forces) applied to them. The requirement to consider hazards from extreme or unusual events is explained in Section 3, where ‘wind’ is highlighted as a potential hazard both during the erection/dismantling stages and during the operational phase. The need to have operational contingency plans is also explained in Section 5 where ‘risk assessments’ and ‘major incident plans’ are discussed.

To enable the structural design to be completed it is necessary to determine the forces acting. These will include wind forces as well as those from other applied loading e.g. vertical loads from the dead weight of the structure, live loads from the occupants and notional horizontal forces as described in Section 9.

When the applied forces and framework layouts have been decided the structure can be analysed to determine what reactions are applied to the ground

and what internal forces exist within the components (checks can also be made for deflections and overturning/sliding, etc.). Only then can the components and foundations be checked for adequacy.

It is important to realise that the analysis may require several separate checks to be made with different combinations of loading. Design for steel or aluminium frameworks will require the use of ‘material and loading factors’ as given by BS 5950^{8.1} or BS 8118^{8.2} respectively. These are used in limit state design and provide the structure with the required degree of safety against failure; these ‘safety factors’ should not be reduced for temporary structures without a very careful risk assessment having been made.

With permanent structures the foundations will provide reactions to the vertical and horizontal forces applied to them from the structure. The applied vertical forces may be negative (uplift), so requiring the foundations to provide resistance to uplift either by way of dead weight alone or by use of friction piles, kentledge or the like. With temporary demountable structures the use of permanent foundations (e.g. concrete pads) will be unlikely unless the structure is used in the same format from year to year. Temporary pad bases will have to provide the reactions to the applied loadings and in the uplift case they will have to be supplemented by either ground anchors or kentledge (added dead weight). Table 6 gives load cases that should be considered when assessing the effects of wind on a structure, other combinations would need to be considered for completion of a full structural design.

Table 6 Load cases for assessing the effect of wind on a structure

Load case	Purpose	Dead (G_k)	Live (Q_k)	Wind (W_k)	Notional (N_k)
W1	Foundations	1.2	1.2	1.2	1.2
W2	Foundations	1.0	0.0	1.4	0.0
W3	Deflection	1.0	1.0	1.0	1.0

Note
If an operational wind speed is selected below that which might be expected at the site then this value may be used in these cases only in conjunction with the wind management option. In this table ‘Notional load’ refers to the values given in Table 12 for Grandstands. For other types of temporary demountable structure that carry live loading, a notional horizontal load should be used (see Table 12).

All structures should possess an adequate factor of safety against overturning. Unless the temporary structure's adjoining sub-frames are very rigidly connected, or the bracing system is continuous throughout, it is unlikely that the whole framework will act as one. If the results from analysis of load cases above show that tension exists in the supporting legs (i.e. negative reactions at the pinned base feet) then either ground anchors or kentledge should be provided. To determine these requirements the following factors of safety should be provided against the resulting factored loads:

- Mechanical Ground Anchors. 1.5
- Kentledge to resist purely vertical loads and not relying on friction. 1.1
- Kentledge to resist inclined loads and relying on friction. 1.5

Kentledge is a more controllable system hence the lower factor of safety specified; mechanical anchors are dependent on ground conditions which may be variable for different parts of the site. Site trials are recommended for large scale applications of ground anchors.

The wind loading to be applied in the analysis of permanent structures in the UK is determined by reference to BS 6399 Part 2 1997^{8.3}. This code of practice is also ideally suited to the design of temporary structures for specific locations and periods of use. Various factors are applied to determine an effective wind speed for the site V_e and this value is used to calculate the dynamic wind pressure q using equation (16) from B6399^{8.3}:

$$q = 0.613 V_e^2$$

An important point to note here is that the dynamic pressure is a function of the effective wind speed squared, which is a non-linear relationship.

Some older existing temporary structure systems will have been designed to CP 3 Chapter V: Part 2: 1972^{8.4}. This allowed a partial factor of 0.77 to be applied for 'temporary' structures, hence reducing the wind speed to take account of the reduced probability of full storm conditions during the relatively short period the structure was exposed. This reduction can be seen to reduce the dynamic wind pressure used in the structural analysis to about 60% of that which would be used for a permanent structure i.e.

$0.77 \times 0.77 = 0.56$. CP3^{8.4} has now been officially withdrawn and should not be used in new analyses.

BS 6399 Part 2 1997^{8.3} allows similar partial factors to be used by taking account of seasonal variations in wind speeds and if necessary by altering a probability factor to accept a greater than usual degree of risk that the design wind speed may be exceeded. This should only be done in the full knowledge of a comprehensive risk assessment. BRE Digest 483^{8.5} (which refers to Stages) gives useful information with respect to the Seasonal Factor S_b which may be used to cater for specific times of usage on site e.g. for 1, 2 or 4 month periods at different times of the year. This may be used for other structures as long as the necessary caution is observed.

When considering wind speeds and forces it is necessary to distinguish between the different terms and values used. Some relevant points are noted below:

Wind speed

For design purposes it is always necessary to establish the gust wind speed as it is the gusts that are the damaging occurrences. Wind speed maps traditionally give values in 'clean' air 10m above ground level. The wind speed map in CP3 Chapter V: Part 2: 1972^{8.4} gave design gust speeds in m/s. The basic wind speed map given in BS 6399 Part 2 1997^{8.3} (see also Figure 12 in this *Guide*) gives hourly mean wind speeds, note that these have to be modified by factors to take account of gust speeds. Gust wind speeds can vary considerably e.g. for a structure up to 20m in height the gust factor varies from 1.07 to 1.90 depending on height and terrain.

In normal design, wind force is based on the probability that the gust speed has a 2% chance of being exceeded in one year. It is therefore quite possible that any structure designed fully to BS 6399 Part 2^{8.3} will at some time or other experience a wind gust in excess of the design value. This is considered a normal risk and acceptable for Building Regulation approval (any excess loading being catered for by partial factors built into the design process that provide the necessary degree of safety). For example, the wind forces will be factored up usually by 1.2 or 1.4 times depending on the load case considered and the material properties may, (e.g. as in the case of aluminium), be modified by partial (safety) factors.

Activity	Tolerable	Unpleasant	Dangerous
Short exposure	B4 5.5-7.9m/s	B5 8.0-10.7m/s	B8 17.2-20.7m/s
Long exposure	B3 3.4-5.4m/s	B4 5.5-7.9m/s	B8 17.2-20.7m/s

Physical effects of wind

BRE Digest 390^{8.6} considers the effect of various wind speeds in m/s on pedestrians, it refers to Beaufort Scale values (bold type in Table 7), it also comments on applicable wind speed ranges for short and long term exposure in sitting or standing locations. These are also given in Table 7.

The Beaufort scale values are hourly mean speeds at 10m above ground in ‘clean’ air. Gusts can be expected to be considerably higher (e.g. possibly up to 90% increase). Long exposure is related to someone sitting in a theatre, so this gives an indication of the period being considered, say 1.5 to 2.0 hours. When considering Beaufort Scales B4 and B5 it should be understood that it is unlikely that outdoor seating, spectator stands and the like would be occupied in these kinds of conditions. However these wind speeds would not necessarily be sufficient to cause abandonment of all types of event. For B8 conditions gust speeds would almost certainly exceed 25m/s at 10m above ground.

Weather forecasting

TV weather forecasts give mean wind speeds in mph up to ‘Gale Force’ (Beaufort scale B8) which indicates mean wind speeds circa 17.2m/s and above. They normally warn of possible ‘structural damage’ and give predicted wind gust speeds. The Met Office can provide 2 and 5 day forecasts for specific locations throughout the UK. In all cases the forecast speeds are those expected to apply at 10m above ground level in open, level terrain. It is advisable not to place sole reliance on internet website forecasts.

8.1.3 Design principles

As BS 6399: Part 2^{8.3} contains limited information on design for temporary structures, it is considered appropriate to allow an alternative approach to design against wind actions for temporary structures such as grandstands, stages and special structures. This may be accomplished by setting a threshold of maximum wind speed for the design of the structure in combination with site monitoring of wind speed and providing an agreed action plan or method statement if the threshold is exceeded.

8.1.3.1 Existing systems

These will have a pre-determined capacity to resist wind forces. If this is not known then it should be determined by analysing the structure using all normal loadings (dead and superimposed, etc.) along with appropriate load factors and by modelling in gradually increasing values of wind loading until the limiting value is found. This will give the ‘Operational maximum wind force’ that can be accepted. By back substituting the design principles of BS 6399 Part 2^{8.3}, using pressure coefficients from that code as needed, the dynamic wind pressure q can be found, this will enable a ‘maximum effective wind speed’, here designated $V_{e,max}$, to be calculated using equation (16) from BS 6399 Part 2^{8.3}.

By knowing the site location, season of use, etc, V_e can be determined for the site in question.

If V_e is less than $V_{e,max}$ then the structure should be safe to use (however it is still recommended that a close watch is kept on the forecast wind speeds as the probability that these may exceed the design capability of the temporary structure is higher than that for a permanent structure at the same location).

If V_e is greater than $V_{e,max}$ then the structure should only be used in conjunction with wind speed monitoring and a suitable action plan, (see later).

It follows from the above that if $V_{e,max}$ can be determined using such factors that are known, or that can be substituted into the equation, the basic wind speed V_b can be found for various configurations of the system. This can then be compared with Figure 6 in BS 6399 Part 2^{8.3} or Figure 12 in this *Guide* to determine suitable locations and seasons of use for the temporary structure. With complex arrangements of structural layout this may be better achieved by way of a computer program.

8.1.3.2 New designs

Here the designer is faced with options:

Option (a) Design for the maximum likely wind forces to be experienced. This may be feasible for certain, crane erected, structural frameworks where considerable dead load will be in place to counteract the effects of wind but it is unlikely to be economic for lighter structures where hand erection and speed of delivery is paramount.

Option (b) Design for a maximum operational wind gust speed that has a high chance of being acceptable in the geographic area that the temporary structure is to be used. For example, design for a maximum gust speed of 25m/s (or any other speed as required, see Section 8.1.2). The value chosen should be considered the effective wind speed V_e used to calculate dynamic wind pressure q in the normal manner.

If using option (b) then an effective wind speed of 25m/s (56mph) would usually be considered an appropriate limit that would not cause too much conservatism or be too likely to trigger the action plan. However it should be appreciated there is a distinct possibility of this value being exceeded in quite a large range of UK venues throughout the year.

The basic wind speed map (Figure 12) shows the minimum basic wind speed to be 20m/s and it is generally assumed that gusts may exceed this by a considerable margin (See Section 8.1.2). Appropriate factors determined from BS6399: Part 2^{8.3} would have to be applied to the structure to see what effects they have in calculating the effective wind speed. Gust factors would tend to increase the value and seasonal factors could be needed to act in a reducing manner to bring the effective speed within the 25m/s threshold.

Critical factors to consider are:

- Will it be possible to evacuate the public and staff from the site, especially if strong winds pick up during the event?
- In the event of the maximum gust speed being exceeded then the possibility of structural failure must be considered.
- Will load reducing measures be possible? e.g. removal of cladding, etc.
- Should additional bracing or kentledge be added?
- Is there a danger from wind blown debris?
- Are exclusion zones practical? These are notoriously difficult to determine due to the uncertainty over the travel of displaced items, etc.

It should also be recognised that on a site containing many differing types of temporary structure the operational wind speed for the event could be set by the weakest structure present, (this may have commercial implications).

8.2 Wind loading on structures

The design principles given in Section 9.3 apply equally to wind loadings. Note that any structure utilising standard structural components in a non-standard manner e.g. sitting on top of other temporary sub-bases or accommodation units or those that have roofs, must be considered a ‘Special Structure’ (see Section 8.2.3).

In the absence of more specific information from tests the pressure coefficients given in BS 6399 Part 2^{8.3} should be used when designing for wind loading.

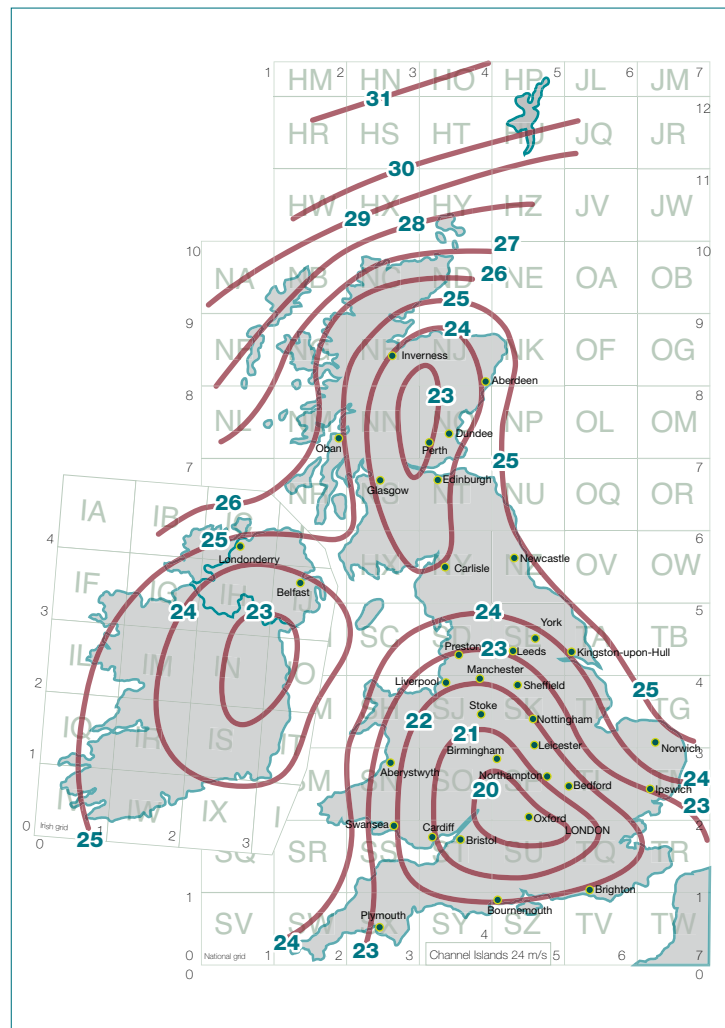

Figure 12 Basic windspeed V_b (m/s) (BS 6399: Part 2^{8.3}). From BRE Digest 346 Part 3^{8.11}

It is critical that the extent of any banners and cladding is clearly defined in the structural calculations. It should be appreciated that adding banners, cladding and the like to a structure can significantly increase the wind loading on a structure and therefore increase the risk of overturning or collapse.

8.2.1 Grandstands

In practice there will be an almost infinite number of loading combinations assuming various degrees of spectator occupancy, and heavier superimposed loads may well act to counteract wind overturning moments. The load cases given in 8.1.2 (Table 6) should be used to consider the effects of wind overturning. If the stands are shown to be susceptible to overturning when empty then they should either be anchored down or have procedures set up to allow removal of cladding, etc to reduce wind loading in times of high wind. Exclusion zones should only be considered as a last resort.

Stands will have varying degrees of permeability to wind i.e. a 150mm rise stand with solid risers will have a much greater degree of wind blockage than a 300mm rise stand with 150mm downstands and 150mm gaps.

In the absence of test data the degree of blockage should be apportioned conservatively. It is recommended that degrees of blockage in the ranges given below should be considered, depending on judgement and knowledge of the actual component dimensions:

- Solid riser stands. 90-100%
- Open riser stands. 50-75%

The effects of security netting or sheeting and other forms of cladding should also be taken into consideration.

Design guidance for grandstands for loads other than wind loads is given in Section 9.

8.2.2 Stages

Because of their relatively large superstructure face area, stages almost always have to be managed structures i.e. the wind case is critical and the wind management procedure, Section 8.1.3.2, Option (b) is essential.

In practice, stage structures should be specifically designed for erection in the same format at each venue (it follows that any 'one-off' stage should be considered a Special Structure see Section 8.2.3). The stage's structure should

be actively controlled, either by the supplier or operator, throughout the event, from erection to dismantling. The design gust wind speed adopted in the design will be a matter of commercial judgement depending on the anticipated usage.

Some concern has been expressed regarding the stability of loose laid stage decks which may be dislodged by wind forces (suction/uplift). Recent research has been carried out by BRE and the results are presented in BRE Digest 483^{8.5}. This should form the basis of any new deck designs and act as an aid to checking existing systems.

In the absence of specific test data then the wind force coefficients given in BS 6399: Part 2 1997^{8.3} for permanent buildings, canopies or for open sided buildings should be used to assess wind pressures/forces acting on the stage or its components.

General design requirements for stages are given in Section 10.

8.2.3 Special Structures

This Section is intended to apply to all structures other than conventionally used grandstands, stages, tents and marquees. The terminology is in line with BS EN 12811-1^{8.7} which is relevant to special 'scaffold structures' such as towers, ramps, etc built with conventional (tube and fitting) scaffolding components. The design guidance in BS EN 12811-1^{8.7} and/or BS 5975: 1996^{8.8} should be followed for such structures albeit wind loading should now be assessed using BS 6399 Part 2 1997^{8.3} (BS 5975^{8.8} still refers to CP3 Chapter V^{8.4}).

Other Special Structures will comprise purpose built buildings such as hospitality units, storage units, offices, etc or such things as screen supports, footbridges or ramps, to be used at sporting venues, outdoor shows or indeed for any other form of commercial use. They will also include non standard usage of common components e.g. where marquees are fixed to the top of either steel or aluminium framed structures or where seating or standing decks are placed upon sub-bases or other structures or have roofs built above them.

All unique Special Structures should be the subject of individual design for the site involved. Relocatable systems intended for use at many varying locations should be checked against the wind loading of the specific site in question to ensure their design capacity will not be exceeded.

Further information about the design of ancillary and special structures is given in Section 13.

8.2.4 Operations management for wind Option (b)

Criteria

This Section outlines requirements for adopting an operational maximum gust wind speed as described in Option (b) of Section 8.1.3.2.

The operational maximum gust speed should be taken as a one-second gust measured at 10m above ground level.

To ensure the safe operation of facilities up to a maximum gust wind speed requires continuous measurement of the wind speed while people are on or around the structure and requires a management plan defining the procedures and actions to be put in place should the operational maximum gust wind speed become likely to be exceeded.

It is suggested that such plans should include two levels of warning to ensure that people on or around the structure are not put at risk:

- **Level 1** When monitoring registers a gust wind speed in excess of 75% of the operational maximum gust speed (measured at 10m above ground level) in conjunction with an increasing general trend of recorded wind speeds, staff should be put on alert that action may be required and if erection is still in progress consideration should be given to delaying further erection.
- **Level 2** When monitoring registers a gust wind speed in excess of 90% of the operational maximum gust speed (measured at 10m above ground level), in conjunction with an increasing trend in the wind speed records, the operational procedures defined in the management plan should be implemented and the site secured against access by the public.

If an isolated gust speed is recorded in excess of 90% of the operational maximum gust speed against a background of a generally falling level of wind speed, a further period of monitoring may be appropriate before implementation of the management plan.

Measurements

All wind speed should be measured in ‘clean’ air avoiding turbulence and shelter from surrounding features. Ideally this will be achieved by siting the anemometer on a 10m high mast which is located at least 60m away from all large obstructions, trees, etc. In many cases this will not be possible and the anemometer will need to be fixed to the temporary structure itself. In this case, the anemometer should be mounted at a height of at least $((1.3 \times H) + 1\text{m})$ where H is the maximum height of the structure on which the anemometer is mounted. Where this is impractical the designer should provide a clear statement as to a suitable alternative location.

Complexes involving many large structures in close proximity may need specialist advice regarding the siting of any measuring devices.

All wind speeds measured are referenced at 10m above ground level. Table 8 gives the appropriate speeds to be used, assuming a limit of 25m/s has been selected, if measurements are taken at different heights. Intermediate values for heights above 5m may be interpolated.

Where wind speeds have been recorded as a result of a Level 1 action, a hard copy of the wind speed record should be kept for inspection if required.

An audible and/or visual alarm system should be provided to warn of exceedance of wind speed Levels 1 and 2.

Table 8 Relationship between gust wind speed and measurement height (assuming a limit of 25m/s at 10m above ground level)

Height (m)	Operation Wind Speed (m/s)	Level 1 Wind Speed (m/s)	Level 2 Wind Speed (m/s)
5	21.5	16.7	19.2
10	25	19.4	22.3
15	26	20.2	23.2
20	26.5	20.6	23.7
30	27.5	21.4	24.6

Notes

a Level 1 is based on 75% of the operational maximum gust speed which corresponds to 60% of the operational load.

b Level 2 is based on 90% of the operational maximum gust speed which corresponds to 80% of the operational load.

There are various types of wind measuring devices available. Those with separate measuring and display units, usually linked by cable, can be obtained from suppliers to the aviation, crane and marine industries. Most of the units available have a facility to trigger a single external alarm, but very few have the facilities to trigger two alarms at different speeds. Several types come with a pre-determined length of wire (typically 20m) and most of these cannot be extended. It is therefore essential to check with the supplier that the device will suit the intended purpose.

8.3 Wind loading on tents and marquees

Design, erection and operation of tents and marquees are discussed in Section 12.

8.3.1 Basis

The design may follow one of two routes. Either follow the procedure set out in BS EN 13782: 2005^{8.9} or the procedure given in 8.3.2 below based on PTA recommendations.

8.3.2 PTA Method

The safety of tents and marquees in wind is assured through a two-stage process.

- 1 Selection of a suitable marquee for the site.
- 2 Active management of risk in service.

This process uses monitoring of the maximum service gust speed at 10m above ground, V_{10} , which is appropriate for the site where the marquee is to be erected. V_{10} should be determined for the erection site from BS 6399: Part 2: 1997^{8.3}, which gives V_{10} as:

$$V_{10} = V_b \times S_a \times S_b \times S_d \times S_s \times S_p \quad [1]$$

The basic wind speed V_b depends on the geographic location of the site. The values of altitude factor, S_a , and terrain and building factor, S_b , depend on the exposure of the site, while the values of direction factor, S_d , seasonal factor, S_s , and probability factor, S_p , depend on the use of the structure.

By standardising the expected range of sites for tents and marquees in the UK, equation [1] simplifies to:

$$V_{10} \approx V_b \times S_{\text{marquee}} \quad [2]$$

where V_b is taken from the wind map in Figure 6 in BS 6399: Part 2^{8.3} (Figure 12 in this *Guide*) and S_{marquee} is taken from Table 9.

8.3.2.1 Large marquees

Large marquees are pole marquees with a span greater than 12m (40ft) or framed marquees with a span greater than 9m. Large marquees should be designed to remain stable for the design wind loading predicted by the Code/Standard relevant at the time of design. This will be:

- CP3: Chapter V: Part 2: 1972^{8.4} for marquees designed prior to August 1995.
- BS 6399: Part 2: 1995^{8.10} or CP3: Chapter V: Part 2: 1972^{8.4} for marquees designed from August 1995 to July 1997.
- BS 6399: Part 2: 1997^{8.3} or CP3: Chapter V: Part 2: 1972^{8.4} for marquees designed from July 1997 to October 2001.
- BS 6399: Part 2: 1997^{8.3} for marquees designed from October 2001.

Compliance with the code requirements should be proved by structural calculations.

For any large marquee, compliance should be defined in terms of the rated maximum service gust speed at a height of 10m above ground, V_{10} for the marquee. It may be practical to rate the canopy and the guying system separately, in which case the lower rated value applies. The rated value of V_{10} for double-guying may be taken as 1.4 times the rated value for single-guying.

Selecting a large marquee for a given site

Using equation [1] or [2], determine the maximum service gust speed V_{10} for the marquee from the site basic wind speed V_b given in Figure 12. Select a marquee which has a rated maximum service gust speed rated higher or equal to this value. If this is not possible, refer to Section 8.3.2.3.

Selecting a suitable site for a large marquee

Given the rated maximum service gust speed V_{10} for the marquee to be used, determine the maximum site basic wind speed V_b using equation [1] or [2].

From equation [1]: [3]

$$\frac{V_b = V_{10}}{S_a \times S_b \times S_d \times S_s \times S_p}$$

or from equation [2]: [4]

$$V_b = \frac{V_{10}}{S_{\text{marquee}}}$$

Ensure that the basic wind speed for the site given in Figure 12 does not exceed this value. If this is not possible, refer to Sections 12.3 and 12.4.

Highest point of marquee above ground		Less than 6m		Less than 9m		Less than 12m	
	Site altitude above sea level	Summer	Winter	Summer	Winter	Summer	Winter
Open sites less than 2km from coast	below 30m	1.24	1.47	1.29	1.53	1.33	1.58
	below 100m	1.32	1.57	1.37	1.64	1.42	1.69
Sheltered sites less than 2km from coast	below 30m	1.10	1.31	1.18	1.40	1.20	1.43
	below 100m	1.18	1.40	1.26	1.50	1.28	1.52
Open sites between 2 and 10km from coast	below 30m	1.21	1.44	1.29	1.53	1.32	1.58
	below 100m	1.30	1.54	1.37	1.64	1.41	1.68
Sheltered sites between 2 and 10km from coast	below 30m	1.05	1.24	1.12	1.33	1.18	1.40
	below 100m	1.12	1.33	1.19	1.42	1.26	1.50
Open sites more than 10km from coast	below 30m	1.18	1.40	1.25	1.49	1.29	1.54
	below 100m	1.26	1.50	1.34	1.59	1.38	1.65
Sheltered sites more than 10km from coast	below 30m	1.01	1.20	1.08	1.29	1.14	1.36
	below 100m	1.08	1.28	1.16	1.38	1.22	1.45

Notes

- a** Sheltered sites are sites generally in towns or sites sheltered from the prevailing wind direction by obstructions (buildings, woodland or dense hedges) that are closer to the tent or marquee than the maximum distance derived from the ratios given in Table 10.
- b** Open sites are all other sites that are not sheltered sites.
- c** For sites above 100m altitude, increase value of S_{marquee} given for 100m altitude by 1% for every 10m altitude above 100m.
- d** BS 6399^{8.3} defines winter as being October through March, and summer as April through September.

Ratio of obstruction height to marquee height	1	1.5	2	3	4	5
Ratio of maximum distance to marquee height	1	4	7	13	19	25

Rating of marquee as % of site maximum service gust speed	Hours unavailable per year	Percentage risk of unavailability
90%	25	0.25%
80%	100	1%
70%	500	6%
60%	2500	30%

8.3.2.2 Small marquees

Experience in use over the long term indicates that small marquees erected to comply with the PTA Code of Practice^{8.12} may be used in winds up to:

- Beaufort Range 5 when single-guyed (gust wind speed equivalent 18m/s).
- Beaufort Range 7 when double-guyed (gust wind speed equivalent 27m/s).

Small marquees that comply with the PTA Code of Practice^{8.12} may be used anywhere in the United Kingdom, provided they are erected and operated in accordance with Sections 12.3 and 12.4. The operational limit for single-guyed small marquees, Beaufort Range 5, is expected to occur for less than 100 hours/year over south-east England. The operational limit for double-guyed small marquees, Beaufort Range 7, is expected to occur for less than 200 hours/year in Shetland and the Hebrides. Strong winds are most likely from the sector from south-west to north-west during the winter months in the UK.

8.3.2.3 Exceptional sites

Active safety management allows the erection of marquees at sites where the maximum service gust wind speed exceeds the rated value for the marquee, provided that the active safety management procedures are properly defined and enforced (see Sections 12.3 and 12.4). However, the possibility then exists that the marquee may not be available for use when required, and the likelihood of this is given in Table 11.

8.3.2.4 Erection and operation

Where there is a choice, the erection site should be sheltered from the prevailing winds (south-westerly to north-westerly in the United Kingdom). The crew should be thoroughly trained in the active safety management procedures and be properly equipped to carry them out. If the maximum service gust speed for the site requires the marquee to be double-guyed, the marquee may be single-guyed until strong winds are forecast, provided provisions for double-guying are provided. This should be normal practice for small tents during the summer period.

Frequent reference should be made to local weather forecasting services to determine the level of active safety management and the size of the crew. Active safety management procedures should be initiated as soon as wind speeds approaching 90% of the maximum service gust speed are forecast. Single-guying should be increased to double-guying, starting

with the windward side of the marquee, and the forecast wind speeds checked against the increased maximum service gust speed. If a marquee cannot be strengthened sufficiently to withstand the forecast wind speeds before they arrive:

- The marquee and its immediate area should be cleared of the public.
- The marquee should be partially dismantled by lowering pole marquees to the ground, and removing the canopy of frame marquees.

8.4 References

Readers are advised to check for updates given to references throughout this document.

- 8.1 *BS 5950-1: 2000: Structural use of steelwork in building. Code of practice for design. Rolled and welded sections.* London: BSI, 2001
- 8.2 *BS 8118-1: 1991: Structural use of aluminium. Code of Practice for design.* London: BSI, 1992
- 8.3 *BS 6399-2: 1997: Loading for buildings. Code of practice for wind loads.* London: BSI, 1997
- 8.4 *CP3: Chapter V Part 2: 1972. Code of basic data for the design of buildings. Chapter 5: Loading: Part 2: Wind loads.* London: BSI, 1972 [withdrawn October 2001]
- 8.5 Blackmore, P. and Freathy P. *Wind loads on temporary stage decks.* Garston: BRE, 2004 (BRE Digest 483)
- 8.6 BRE. *Wind around tall buildings.* Garston: BRE, 1994 (BRE Digest 390)
- 8.7 *BS EN 12811-1: 2003: Temporary works equipment. Scaffolds. Performance requirement and general design.* London: BSI, 2004
- 8.8 *BS 5975: 1996: Code of practice for falsework.* London: BSI, 1996
- 8.9 *BS EN 13782: 2005. Temporary Structures. Tents. Safety.* London: BSI, 2005
- 8.10 *BS 6399-2: 1995: Loading for buildings. Code of practice for wind loads.* London: BSI, 1995 [withdrawn July 1997]
- 8.11 BRE. *The Assessment of wind loads. Part 3: Wind climate in the United Kingdom.* Garston: BRE, 1989 (BRE Digest 346, Part 3)
- 8.12 Made-Up Textiles Association. *A code of practice for marquee hiring contractors and code of public safety: use and operation of marquees.* Tamworth: MUTA, 2001

SECTION 9 GRANDSTANDS

This Section is intended particularly for clients, designers, contractors and suppliers of temporary structures

“Design of temporary grandstands should be the responsibility of a competent person. Before assembly, the design and engineering documentation, including calculations, drawings and specifications should be independently checked by a chartered engineer of appropriate skill and experience.”

“Demountable framed structures should be designed to form a robust and stable three-dimensional structural arrangement which will support the design loadings for the required period with an adequate margin of safety.”

“Demountable structures should possess sufficient transverse and longitudinal stiffness and strength to resist wind loads, notional horizontal loads and other dynamic loads induced by spectator movements.”

“Dynamic loads will only be significant when any crowd movement (dancing, jumping, rhythmic stamping, etc.) is synchronized and periodic. In practice this only occurs in conjunction with a strong musical beat, at events such as lively pop concerts. The dynamic load is thus related to the dance frequency or the beat frequency of the music and is periodical. Such crowd movement generates both horizontal and vertical loads. If the synchronized movement excites a natural frequency of the structure, resonance will occur which can greatly amplify its response.”

9 GRANDSTANDS

9.1 Introduction

Design of temporary grandstands should be the responsibility of a competent person. Before assembly, the design and engineering documentation, including calculations, drawings and specifications should be independently checked by a chartered engineer of appropriate skill and experience. The contractor may appoint the engineer for the independent design check. For a standardised temporary structure which is erected in exactly the same form to the same design at different sites, the design does not need to be checked every time the structure is erected. However, see Section 6.

Temporary demountable grandstands are used at a wide spectrum of events both indoors and outdoors, ranging from minor local events to major international events accommodating thousands of spectators.

The term ‘grandstands’ is taken to include standing accommodation, seating accommodation, structures which consist of both types, and enclosed hospitality accommodation with viewing balconies or windows.

9.2 Materials

Temporary demountable grandstands incorporate elements from a range of materials including steel, aluminium, timber, plywoods, textiles, paints and plastic

components. Where materials, components and methods of design and construction are not specifically covered by BS EN Standards, the designer should be satisfied that the materials and methods to be employed are such as to ensure sufficient levels of safety, durability, integrity, strength, serviceability and performance. Alternatively, a test assembly should be built to test the structure, component, material or method under consideration. The test assembly should be representative, as to materials, workmanship and details, of the design and construction for which approval is sought.

Small seating structures may consist of scaffolding while large ones often include standard prefabricated components. Combinations of systems may also be used, e.g. the lower parts of scaffolding create a level platform for a proprietary seating system.

Proprietary stands or components from different manufacturers or systems should not be used as part of the same structure unless the designers of both systems agree they are structurally compatible and specify how they should be connected.

9.3 Design principles

The type of structure under consideration, namely temporary demountable stands, may be simply described as a seating deck of a stepped tiered nature supported by a substructure possessing large numbers of common elements. (See Figures 13 and 14).



Figure 13 Temporary grandstands erected for a tennis tournament

A seating place is required to provide a minimum viewing standard together with a sufficient level of safety for the spectator body. Viewing standards refer to the ability of a spectator to see a predetermined focal point in the activity area. This viewing standard is often referred to as a sight line.

The layout of the spectator deck and the geometry of the deck are required to provide for the safe ingress and egress of spectators.

Barriers to the perimeter of the structure and within the spectator deck provide protection against falling.

The supporting structure is required to safely resist the static and dynamic forces created by the spectator body and other dynamic forces that are required by applicable national standards.

Criteria concerning sightlines, layout and protection from falling are common to permanent and temporary seating decks. The nature of vertical support of permanent and temporary seating decks is significantly different. Similarly, the ratio of live load to dead load is much higher for temporary structures than permanent structures.

Demountable framed structures should be designed to form a robust and stable three-dimensional structural arrangement which will support the design loadings for the required period with an adequate margin of safety. Structural scaffolding or purpose-

built modular units may be used to support the seating deck (Figures 13 and 14). Components are often designed to be handled by one person.

The integrity of demountable structures should be such that the consequential effects of accidental damage or vandalism should not be disproportionate. By virtue of their lightweight construction and use, temporary structures are often exposed to risks of accidental damage by vehicles, unauthorised removals and alterations, etc. This fact should be carefully considered by the designer when assessing stability and associated redundancy.

Because demountable structures often need to be erected quickly, they are usually of lightweight construction with temporary foundations or supports; they are therefore relatively sensitive to dynamic excitation. This *Guide*, therefore, addresses the design requirements to cater for both static and dynamic loading and gives recommendations on the appropriate load combinations.

Structures with more conventional structural formats should be designed by normal design requirements, such as BS 6399^{9.1}, 9.2, 9.3 BS 5950^{9.4} and BS 8118^{9.5}.

The load capacity of each element and its connections as determined from the relevant British Standards should not be less than the most unfavourable but realistic factored load which will be experienced by that member.



Figure 14 Temporary grandstand erected for a golf tournament

Overall stability should be checked using the procedures defined in the appropriate material standards such as BS 5950 and BS 8118. In all cases, the restoring moments and forces should be greater than the overturning moments or uplift or sliding forces by a margin of at least 1.5. Where necessary, kentledge and/or anchorage to the ground should be provided to ensure adequate resistance to overturning, uplift and sliding.

Demountable structures should possess sufficient transverse and longitudinal stiffness and strength to resist wind loads, notional horizontal loads and other dynamic loads induced by spectator movements. Bracing or stiff frames should be provided regularly on transverse and longitudinal planes and should extend over the full height of the structure. Recognition should also be given to the possibility that only parts of the demountable structure might be subject to imposed spectator loads at any time.

Bracing should be provided to transmit lateral loads from spectator action and wind loads to transverse and longitudinal bracing lines. The design of bracing systems should take account of requirements for avoiding disproportionate collapse. The structure should be designed with sufficient bracing so that removing up to two adjacent bracing members would not initiate a collapse. Design of the bracing systems should also take into account the dynamic stiffness of the structure and the effects of dynamic loads from spectator movements^{9.6}. Bracing design requirements may be dictated by connection and/or coupler capacities and this possible restriction should be carefully considered.

Those responsible for demountable grandstand structures should have an appreciation of crowd behaviour and of the hazards that may arise. Sightlines are particularly important.

General advice on standing decks and Layout Criteria may be found in Sections 12 and 14.10 of the *Guide to Safety at Sports Grounds*^{9.7} and BS EN 13200-1 Spectator Facilities – Layout Criteria for Spectator Viewing Area^{9.8}.

Temporary structures should meet the safety standards of permanent structures irrespective of crowd safety measures, and a risk assessment for any detail points that do not comply should be undertaken.

The provision of barriers and handrails should comply generally with the requirements of Section 10 of the *Guide to Safety at Sports Grounds*^{9.7}, BS EN 13200-3 Spectator Facilities – Separating Elements^{9.9} and BS EN 13200-6 Spectator Facilities – Demountable (Temporary) Stands^{9.10}.

9.4 Design guidance

9.4.1 General

Temporary demountable stands should be designed in accordance with the appropriate standards and codes of practice. Seating structures should be capable of resisting all loads imposed by their foreseeable use with adequate safety margins. Temporary demountable stands that provide either seating or standing places shall be able to withstand the characteristic actions in accordance with EN 1991 Eurocode 1: Actions on Structures: Part 1^{9.11} or the loads specified in the appropriate British Standard.

Three main categories of use should also be considered as in Table 12.

9.4.2 Loading

The loading appropriate for the design of temporary demountable stands comprises dead, imposed, wind and notional horizontal loads and may require consideration of dynamic loads from crowds.

Dead loads (see BS 648^{9.12} and EC1: Part 1^{9.11}) result from the self-weight of all fixed elements which form part of the demountable structure.

Imposed loads are specified in BS 6399: Parts 1^{9.1} and 3^{9.3} and include loads from spectators, moveable equipment and, where appropriate, snow.

Eurocode 1: Part 1.1 and BS 6399 Part 1 consider various categories of loading appropriate to the type of activity/occupancy for the part of a building or structure. Category C in Eurocode 1: Part 1.1 concerns areas where people may congregate. The divisions of this within the Eurocode that are relevant to grandstands are C2, C3 and C5. The Eurocode gives ranges of imposed loads for these but also gives a recommended value. These ranges are Nationally Determined Parameters and so specific values can be set in National Annexes. The UK has chosen to sub-divide the categories given in the Eurocode. The relevant Eurocode and UK National Annex categories, together with the value(s) of imposed loading are given in Table 13. The recommended values from the Eurocode are given in **bold** numbers.

The quoted values are characteristic values. All floors should be designed to carry the uniformly distributed load derived using appropriate load factors.

Vertical imposed loads shall be taken into account as quasi-static actions. The load models may include dynamic effects if there is no risk of resonance or other significant dynamic response of the structure.

Table 12 Notional horizontal loads for design of temporary demountable grandstands (as a percentage of the vertical imposed load specified in BS 6399: Part 1: 1996)

Category of spectator activity	Notional horizontal load
<p>Category 1 Nominal potential for spectator movement, which excludes synchronised and periodic crowd movement, e.g. at:</p> <ul style="list-style-type: none"> lectures/exhibitions display/shows athletic events golf tournaments agricultural shows military tournaments. 	6%
<p>Category 2 Potential for spectator movement more vigorous than Category 1. Category 2 excludes synchronised and periodic crowd movement, e.g. at:</p> <ul style="list-style-type: none"> major musical concerts rugby or football matches. 	7.5%
<p>Category 3 Stands with a potential for synchronised and periodic crowd movement and having vertical and horizontal fundamental frequencies which avoid resonance effects, e.g. at most pop concerts where strong musical beats are expected.</p>	10%
<p><i>Notes</i></p> <p>a Partial factors for dead and imposed loads for use in the limit state design of grandstands should correspond to the structural code of practice relevant to the material (steel, aluminium, etc.). For notional horizontal loads, the partial factor should be 1.5 for the load combination case with factored values of vertical dead and imposed loads.</p> <p>b The notional horizontal load should be combined with the operational wind load for designing the structural elements of a grandstand but not in the design against overturning as a result of wind action (see Section 8.2.3).</p> <p>c The above figures include an allowance of 2.5% to cover geometrical imperfections, such as lack of verticality.</p>	

Table 13 Imposed uniformly distributed loads for grandstands from Eurocode 1

Category and sub-category of loaded area	Eurocode category UK National Annex sub-category	kN/m ²
C2	Areas with fixed seating	3.0 – 4.0
C21	Assembly areas with fixed seating	4.0
C3	Areas without obstacles for moving people	3.0 – 5.0
C33	Aisles	4.0
C35	Stairs and landings	4.0
C5	Areas susceptible to large crowds	5.0 – 7.5
C51	Assembly areas without fixed seating (see Notes a and b from the National Annex, which are reproduced below)	5.0
<p><i>Notes</i></p> <p>a For grandstands and stadia, reference should be made to the requirements of the appropriate certifying authority.</p> <p>b For structures that might be susceptible to resonance effects, reference should be made to National Annex clause 2.1.</p> <p>c Clause 2.1 in the UK National Annex gives advice which is similar to that given later in Section 9.4.2 of this Guide.</p>		

Overcrowding is considered here to be spectator occupancy of a space greater than would arise during expected use.

Wind loads for the UK are given in BS 6399: Part 2^{9.2}. For design of temporary stands according to Option (a) in Section 8.1.3.2, the duration and season of exposure may be taken into account to make appropriate reductions to the design wind loads.

For demountable structures of unusual configuration, form or location (such as closely spaced groups of structures or structures close to other structures) the assessment of wind load may require specialist knowledge where consideration of both quasi-static loadings and dynamic effects may be necessary, along with both overall and localised effects. In combination with the dead, imposed and wind loads, allowance should be made for notional horizontal loads.

These notional horizontal loads are intended:

- To ensure that the structure can resist horizontal loads induced by spectator action, and
- To take account of the geometrical imperfections of frames, such as lack of alignment of vertical members which transfer the loads from the deck to the ground.

The notional horizontal loads should be taken as a percentage of the imposed load from the appropriate category in Table 12, and considered to act at the node points where the vertical imposed loads are transferred to the vertical members. The notional horizontal loads are the minimum to be used for design purposes and should be treated as unfactored or characteristic loads. For temporary demountable structures, these notional horizontal loads should be applied in combination with the operational wind loads. Empty stands should be designed to resist the worst case wind loading. Notional horizontal loads should only be taken into consideration when stands are occupied.

Appropriate values of imposed loads should be used depending on whether stands are empty or occupied.

Recommended load combinations and the corresponding partial factors for steel structures may be found in Section 2 of BS 5950: Part 1^{9.4} and for aluminium structures in Tables 3.1, 3.2 and 3.3 of BS 8118^{9.5}. Where other materials are used, the designer should adopt appropriate partial factors. It should be noted that, when applying these codes to temporary demountable structures, it is recommended that:

- The factor of safety against overturning should not be less than that recommended in Sections 6.5 and 8.1.2.

- The load combinations should include notional horizontal loads combined with operational wind load. See Table 6.
- The notional horizontal loads should be applied separately for designing plane frames in the longitudinal (side to side) direction and in the transverse (front to back) direction.
- The horizontal sway deflection should not exceed height/300 under the combined effect of the full unfactored dead, imposed and notional horizontal loads acting in conjunction with the operational wind loads.

Temporary demountable grandstands are relatively flexible structures which will respond dynamically to spectator movements.

Dynamic loads will only be significant when any crowd movement (dancing, jumping, rhythmic stamping, etc.) is synchronized and periodic. In practice this only occurs in conjunction with a strong musical beat, at events such as lively pop concerts. The dynamic load is thus related to the dance frequency or the beat frequency of the music and is periodical. Such crowd movement generates both horizontal and vertical loads. If the synchronized movement excites a natural frequency of the structure, resonance will occur which can greatly amplify its response.

Tests on temporary grandstands^{9.13} have indicated that dynamic loads are unlikely to be significant if the crowd movements are not synchronized and not periodic in nature. Such loads would include, for example, those resulting from crowds rising from seating when a performer appears on stage at a pop concert, or a goal is scored at a football match. However, these activities may still produce perceptible movement of the structure.

For temporary grandstands, a simple design approach would involve designing the structure to account for spectator activity using the notional horizontal loads given in Table 12.

Figure 15 is intended to help designers to identify the appropriate category of spectator activity and design approach.

For stands which may be subject to synchronised and periodic crowd movements, the easiest approach would be to estimate the vertical and horizontal natural frequencies and to ensure avoidance of significant resonance effects, as explained in Annex A of the October 2002 amendment of BS 6399: Part 1: 1996^{9.1}. If this can be achieved, the stands can be designed according to the simple design procedure, using notional horizontal loads given under category 3 of

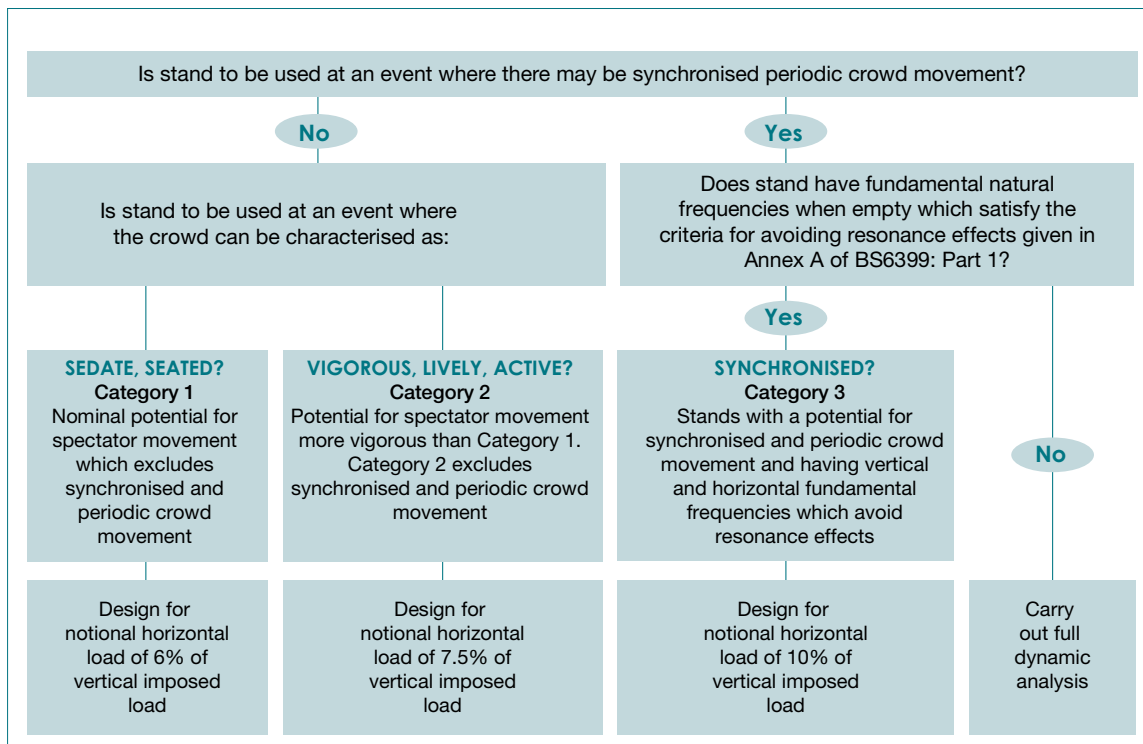

Figure 15 Identifying the appropriate category of spectator activity and design

Table 12. Evaluation of natural frequencies may be by calculation, measurement or type approval. If it is not possible to avoid the resonance effect in this way, design of the stand will require a rigorous analysis to assess the effect of dynamic loads arising from the anticipated resonance effect (see reference 14).

9.5 Connections

Since the connections of demountable structures are reused many times, they should be subject to a regime of inspection. This will normally be visual and checks will be made for distortion, cracking, stripping of threads, undue play, corrosion and other undesirable faults. The checks should be made at the time of erection as part of the normal routine. Section 7.3 discusses this in detail.

Connections should be able to transmit the required design forces. Since they are reused, they should have a margin of additional material to compensate for wear.

Particular care should be given to cable and guy rope terminals. Proper thimbles or eyelets should be used, and shackles, rigging screws and similar fittings may be fitted with split pins or locking devices to aid retention. Small components are easily lost after several erection and dismantling cycles. The connections should be fully checked by a competent person each time the structure is erected.

Where scaffolding is used for the construction or part construction of a stand to which the public has access, the couplers should be to either Class A or Class B to BS 1139: Part 2^{9.15}. They should also be fitted in a way that will ensure they will perform according to those class specifications, i.e. with correctly torqued securing bolts or correctly driven-home wedges, etc. Low loadbearing or non-loadbearing fittings should not be used in such structures.

9.6 Loading tests

Load tests are a permissible way of demonstrating the structural performance of a temporary structure, if not proven by calculation. They should be carried out in accordance with the appropriate material codes: Section 7 of BS 5950: Part 1^{9.4} and Section 8 of BS 8118: Part 1^{9.5}. The responsibilities and liabilities for associated costs will depend upon who requires such a test, and the results of the test.

The loading system should adequately simulate the magnitude, distribution and duration of the loading and allow the structure to behave in a manner representative of service conditions.

No single test can represent all of the load combinations used in design. An exception might be a comprehensive series of tests instigated by a specialist

contractor to prove the adequacy of a standard system which is to be fabricated in volume.

In general, load tests should be regarded as a last resort, especially bearing in mind the short lead times under which the industry operates. It is normally cheaper and quicker to install additional strengthening and stiffness. However, there are instances when the contractor chooses or is requested to offer proof tests to substantiate the frameworks being proposed. Such tests may be necessary when, *inter alia*:

- The contractor is unable to produce proper calculations or when a framework or constituent part is not amenable to reliable calculation.
- Verification is required that the dynamic response to spectator movements will be acceptable.
- There is doubt whether the quality of materials or workmanship is of the required standard.
- Materials or design methods are used other than those of relevant material standards or codes of practice.

9.7 Layout criteria (means of escape)

Any escape system from a demountable grandstand should be such that its use is integrated with the site or building in which the grandstand is located. There should be enough evenly distributed exits from a structure to evacuate it in an emergency without endangering the lives of spectators. The exits should allow spectators to reach a place of safety or a final exit safely without local overloading of stairs, passageways or routes around the site or building. The aggregate flows of individual escape staircases should be no greater than the intermediate or final exit flows into which they discharge. Practical considerations may allow exceptions to this requirement but in this case a risk assessment of the planned route should be made.

Staircases or passageways within stands should be of even width and should not narrow into funnels so as to cause crowds to compress on their journey to a final exit.

Further guidance is given in BS 5588^{9.16}, BS EN 13200-1 (Layout Criteria)^{9.8} and the *Guide to Safety at Sports Grounds*^{9.7}.

Handrails of adequate strength and appropriate height should be provided (see Section 9.8). All decking, aisles and steps on grandstands should be made from or covered with non-slip materials and have adequate non-slip, light coloured step nosings.

9.8 Barriers and handrails

9.8.1 General

Barriers are necessary at the front and rear of seating blocks and along the edges at the sides of demountable stands. With seated audiences or spectators, the seating itself limits the density of the crowd that is able to exert force in any one particular area of barrier. However, in other locations such as the ends of radial gangways, lateral gangways or landings with right angle turns, and to a lesser extent parallel to gangways, crowd loadings will be higher.

9.8.2 Protection against falling

Figure 16 is a plan view of a small elevated seating structure. The seating deck will require a perimeter guardrail, elements of which serve various purposes and are subject to different design loadings.

Type A provides for the safety of individuals moving along a gangway or using a stairway in a direction parallel to the guardrail. 2 kN/m.

Type B provides for the safety of individuals subjected to forces arising from spectators moving in a direction perpendicular to the guardrail direction. Individuals in a gangway or on a stairway can create considerable horizontal forces on this guardrail through pushing or as a consequence of a domino collapse down the gangway or stairway. 3 kN/m.

Type C provides for the safety of individuals entering and exiting seats in the front row. 1.5 kN/m.

Type D provides for the safety of an individual occupying a seat adjacent to the guardrail. 1 kN/m.

Type E provides for the safety of individuals at the rear of the stand. 1 kN/m.

The magnitude of applicable design forces should be assessed after consideration of the geometrical arrangement of the structure. The possibility of disorderly egress may need to be considered.

BS EN 13200-3 Separating Elements-Specification^{9.9} provides guidance and EN 1991 Eurocode 1: Actions on Structures: Part 1^{9.11} together with its UK National Annex should also be consulted.

It is recommended that any element of a guardrail or grandstand should be constructed such that a 100mm diameter sphere cannot pass through any part.

The minimum height of a guardrail is 1m and the recommended height is 1.1m. The height of guardrails

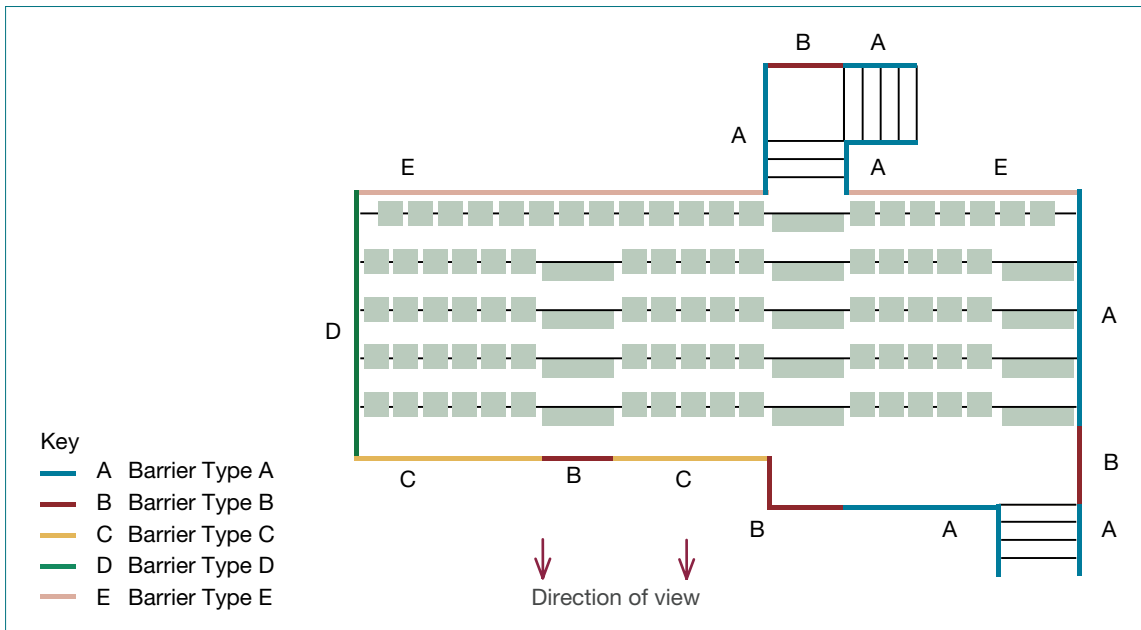

Figure 16 Differing requirements for perimeter guardrails on an elevated seating structure

situated behind the rear or top row of seats (Type E) should be 1.1m, measured from the seat level.

Guardrails that interfere with sightlines can be reduced to a height of 800mm other than where they protect spectators in an aisle or lateral gangway. If a guardrail height of less than 900mm is used a risk assessment is mandatory.

Inset gangways (aisles) in a seating deck are not classified as staircases and as such do not normally require additional railing. Guardrail Type A should be specified for end gangways.

The standards mentioned in this Section should apply to demountable structures used at both outdoor and indoor venues.

9.8.3 Design of barriers

Advice on design, construction and maintenance of barriers is given in BS 6180^{9.17}. Where the construction is not specifically covered by BS 6180, designers and contractors should satisfy themselves that the materials and methods employed will provide durability, integrity and performance at least equal to that recommended in the standard.

Where a demountable structure is to be used at a sports ground specific technical standards relating to barriers and handrails will apply.

Further guidance is given in *Guide to Safety at Sports Grounds*^{9.7} and BS EN 13200-3 Separating Elements^{9.9}.

Front-of-stage barriers are discussed in Section 11 of this *Guide*.

9.9 Demountable standing accommodation

Standing accommodation may be provided by a demountable structure, schematically illustrated in plan in Figure 17, in order to enhance viewing of various events.

The accommodation provided shall be considered as Category C5 (sub-category C51).

The criteria and recommendations given in BS EN 13200-1: Layout Criteria for spectator viewing area and BS EN 13200-3: Separating Elements shall apply as regards riser and tread geometry, barrier loadings and guardrail configuration.

The crush-barrier configuration may comprise multiple rows of guardrails. The tread and riser

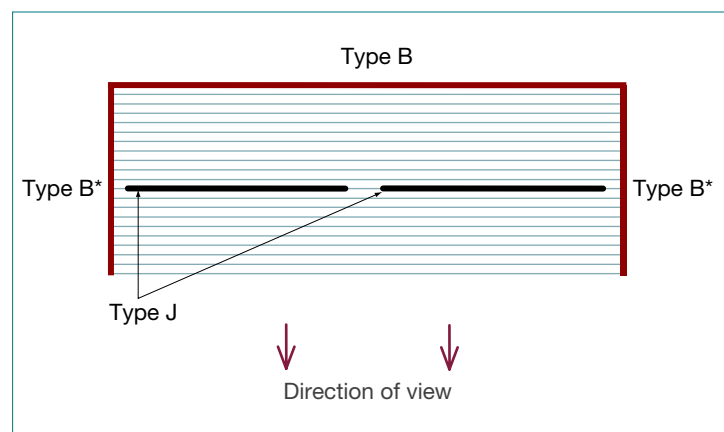

Figure 17 Guardrails for standing accommodation

geometry will determine the spacing of guardrail Type J (crush barriers for standing accommodation) and the characteristic load requirement shall accord with BS EN 13200-3: Separating Elements.

In the absence of an appropriate risk assessment guardrail Type B* is required to resist a characteristic loading of 3 kN/m.

Where the nature of the spectator body is considered as a design factor this shall be recorded in the risk assessment associated with the use of the structure.

Further guidance is given in *Guide to Safety at Sports Grounds*^{9.7} and BS EN 13200-3 Separating Elements^{9.9}.

9.10 Viewing facilities for wheelchair users

9.10.1 General

Probably nothing has changed quite so dramatically in stadium design in recent years as the focus on the needs of disabled spectators and the requirements for inclusion rather than exclusion.

Whilst the temporary nature of a demountable structure may mean that building regulations are not applicable, the person responsible for the event will still have a duty under the Disability Discrimination Act 2005^{9.18} (DDA 2005). Under Part 2 of the DDA, a provider of goods, facilities services or premises is required to make 'reasonable adjustment' to ensure facilities do not discriminate against disabled spectators. This may include avoiding physical barriers to access.

Comprehensive guidance on access issues may be found in the British Standard Code of Practice, BS 8300:2001 – The design of buildings and their approaches to meet the needs of disabled people – Code of Practice^{9.19}.

Where building regulations are applicable, particular reference should also be made to:

- In England and Wales – Building Regulations 2000. Approved Document Part M – Access to and use of buildings 2004 ed^{9.20}.
- In Scotland – Section 4 (Safety), SBSA Non-domestic Technical Handbook (2007)^{9.21}.
- In Northern Ireland – Technical Booklet R – Access to and use of buildings (2006)^{9.22}.

In order to assist football clubs (and other stadium sports in particular) to understand their responsibilities under the DDA and building regulations, the FLA published specific guidance entitled *Accessible Stadia*^{9.23} with the assistance of ODPM, Sport

England and NADS, the National Association of Disabled Supporters.

Following public consultation the following clause was inserted "Prefabricated, temporary or demountable stands all come under the same criteria as conventional construction and need to satisfy the same criteria for numbers, dispersal and viewing quality for disabled spectators. If these criteria cannot be achieved within the stand, alternative and satisfactory provisions may be acceptable".

The requirements for all buildings are quite onerous and the need to satisfy 'reasonableness' might be difficult in some circumstances to determine, hence the need for the guidance. However it is clear through the above how a permanent structure might satisfy reasonableness and hence that must always be the ultimate aspiration. This should be set out in an 'access statement' (Building Regulations in England and Wales recommend providing this) to demonstrate how the needs of spectators will be satisfied. Recording how issues have been considered and the manner in which they are addressed will assist in demonstrating how a service provider has met their responsibilities under the DDA.

The needs for all disabled spectators are required to be considered i.e. in addition to spectators in wheelchairs, the needs of ambulant disabled persons and those with hearing and visual impairments have to be taken into account.

9.10.2 General principles

The design has to start with the location. It is essential that the platform and its occupants do not block the sight lines of other attendees. Failure to address this may result in crushing around the platform.

The essential requirement is to enable wheelchair users to see whilst not raising them to the point of feeling they are 'on show'. At most typical events, where a standing audience is watching entertainment on a stage of at least 1.2m (4ft.) high, the wheelchair users platform height is likely to be between 1.1m and 1.25m. (Stages with a platform height of less than 1.2m are usually unsuitable for a standing audience on a level site).

As with all event goers, wheelchair users need access to facilities such as toilets and concessions, which again can affect the choice of location.

Many wheelchair users need to have an able bodied assistant or simply wish to share the occasion with a friend. The friend may or may not be a wheelchair user. Where able bodied assistants/friends are accommodated on the platform, it is essential that

there is a management plan to ensure they remain seated if this would interfere with the view of people standing behind the platform.

The orientation should also be considered. Where possible the platform should face squarely to the entertainment. Oblique angles are both uncomfortable for the wheelchair users and may reduce the platform capacity due to having to partially turn each wheelchair.

The access ramp has a critical safety function in the event of an evacuation. The ramp and the area it leads to should be treated as an escape route and be kept clear and safe from the risk of fire.

Consideration should be given to providing a staircase access located away from the access ramp. This enables able bodied users of the platform to access and exit the platform without waiting for wheelchair users on the ramp. In the event of an emergency evacuation a staircase provides access for emergency personnel whilst the ramp is being used to evacuate wheelchair users.

9.10.3 Design requirements – platforms

Platform height

See Figure 18.

Surface

The surface of the platform should be level and free of bumps and gaps. Scaffold boards or battens are not considered to be a suitable surface, unless overlaid with 18mm plywood, firmly screwed into place.

Edge protection

Given the number of able bodied people that may be on the platform, barriers should be fitted to the normal standards for a public venue.

Consideration should be given to avoiding the eyeline height of most wheelchair users. However, the height of the front barrier should be a minimum of 0.8 metres.

The front edge of the platform should have a toe-board or upstand to prevent the front wheels of wheelchairs from dropping off the edge.

Infill

Apart from the usual requirement to position a skirt around the platform to hide the sub-structure, consideration should be given to extending this up to the handrail. This provides a useful ‘modesty’ screen and provides some degree of shelter from the wind. The resultant loads from the wind must be considered in the structural design of the platform.

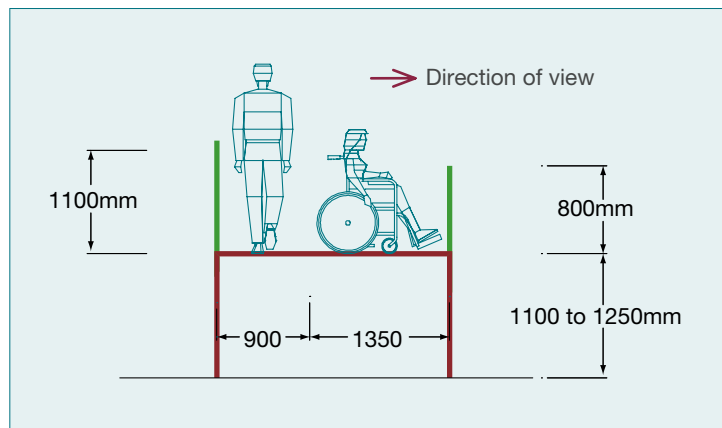

Figure 18 Wheelchair platform height

Signage

The access points to the platform should be clearly signed to indicate the platform is for the use of wheelchair users.

Loadings

It is entirely possible that in the event of a stewarding failure, large numbers of people could gain unauthorized access to the platform. Platform surfaces including the ramp should therefore be designed to the accepted standards for public assembly spaces (See BS6399 Part 1^{9.1}) that requires a capacity of 5kN/m².

9.10.4 Design requirements – access ramps

Access ramp(s)

The failure to supply a suitable ramped access is one of the most common problems with platforms currently available. Key requirements are:

Correct angle

Absolute maximum angle of 1:12. An angle of 1:15 is strongly recommended. There should be intermediate level landings areas to provide rest areas. It is recommended that the longest travel distance between landings should not exceed 8.0m. Very often such landings can also be used at changes of direction, see below.

Suitable size

A ramp should be between 1.0m and 1.3m wide, measured at the narrowest point (i.e. between handrails etc.). It is not recommended to be any narrower as there is a distinct risk of wheelchair users catching themselves or part of the chair on the handrail system. It is also not recommended to be any wider as this could allow a wheelchair to turn sideways across the ramp with a higher risk of overturning.

Changes of direction

Given that some wheelchairs will be pushed up the ramp by an able-bodied assistant, or may be of greater than usual length, any change of direction should have greater dimensions than the width of the ramp.

A change of direction must only be accomplished with a level landing. Each leg of the ramp should have a minimum landing length of 2.0m when measured in the direction of travel from/to that leg.

Non-slip surface

Normal plywood is extremely slippery when wet and conventional paints do little to improve this. Given that wheelchair users will be relying on friction between the ramp surface and their wheelchairs, and some users may be assisted with able bodied people pushing or holding, then the non-slip surface is critical to maintain safety.

In any event the ramp should be free of gaps and uneven surfaces, ridges etc.

Edge protection

The ramp should have normal handrails for the use of able bodied people and should have suitable edge protection to prevent wheels slipping off the edge. An upstand of around 75mm in height has been found sufficient for this.

Visual identification

The ramp edges should be painted in a contrasting colour to the ramp surface for the benefit of people with impaired vision. The two best contrasting colour combinations for people with one or other form of 'colour-blindness' are Black/White and Blue/Yellow. The use of greens and reds is not recommended.

9.10.5 Seating arrangements and capacities

The optimum seating arrangement is to have a quantity of fold-flat or similar chairs available and allocate these as each user arrives. Wheelchairs can be positioned side by side, with a chair behind or chairs can be interspersed with the wheelchairs, according to the requirements of the users. Where gangways are limited it is essential they are not blocked by seats for able-bodied assistants.

Platforms for a single row of wheelchairs

Each wheelchair should be allowed an area 0.90m wide and 1.35m deep. Assuming that one row of wheelchairs is at the front of a platform, there should be a gangway behind this first row of at least 0.9m wide.

This dictates that the minimum platform depth for a single row of wheelchairs is 2.25m (see Figure 19).

Platforms for a double row of wheelchairs

A platform with two rows of wheelchairs can still operate satisfactorily with a single gangway between the two rows, giving a minimum platform depth of 3.6m (see Figure 20).

Platforms for a triple row of wheelchairs

Where 3 rows of wheelchairs are to be accommodated, then two gangways are required (behind the first row and in front of the third row). This requires a platform depth of a minimum 5.85m (see Figure 21).

Capacities

When determining the number of wheelchairs and chairs within a row, widths of 0.9m and 0.5m should be assumed for wheelchairs and folding chairs respectively (see Figure 22).

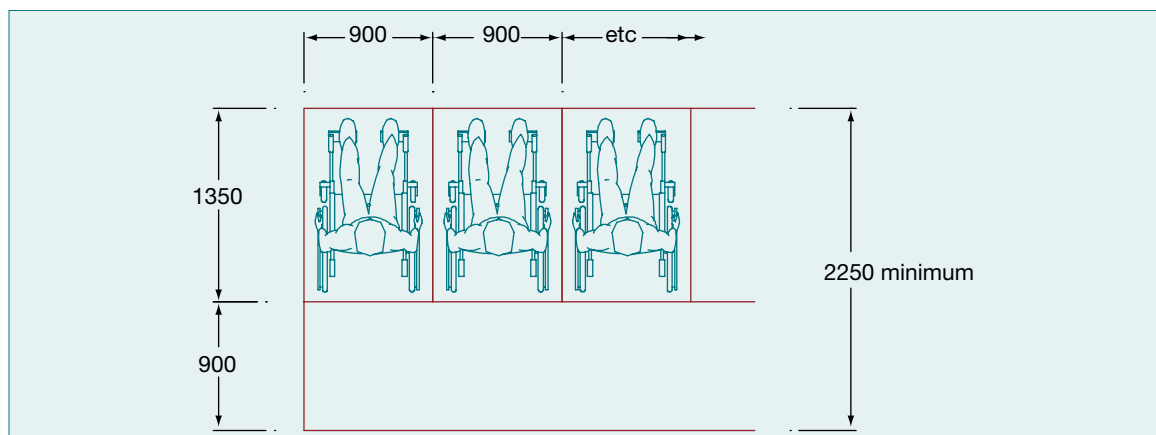

Figure 19 Platforms for a single row of wheelchairs

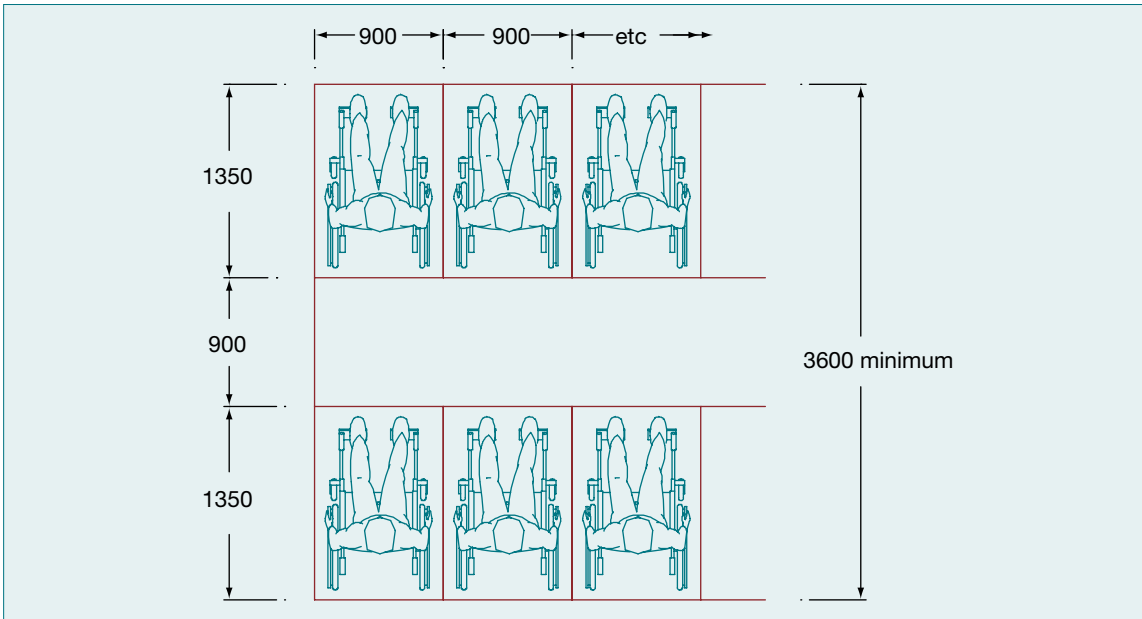

Figure 20 Platforms for a double row of wheelchairs

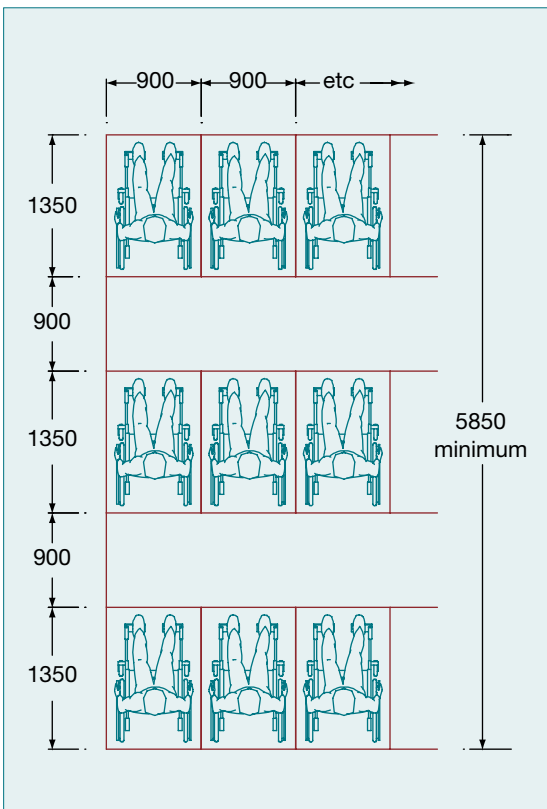

Figure 21 Platforms for a triple row of wheelchairs

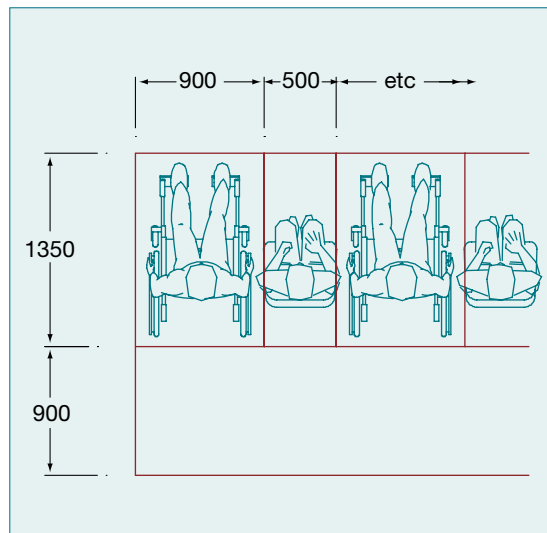

Figure 22 Capacity of platforms

9.11 References

Readers are advised to check for updates given to references throughout this document.

- 9.1 *BS 6399-1: 1996: Loading for buildings. Code of practice for dead and imposed loads.* London: BSI, 1996
- 9.2 *BS 6399-2: 1997: Loading for buildings. Code of practice for wind loads.* London: BSI, 1997
- 9.3 *BS 6399-3: 1988: Loading for buildings. Code of practice for imposed roof loads.* London: BSI, 1988
- 9.4 *BS 5950-1: 2000: Structural use of steelwork in building. Code of practice for design. Rolled and welded sections.* London: BSI, 2001
- 9.5 *BS 8118-1: 1991: Structural use of aluminium. Code of Practice for design.* London: BSI, 1992
- 9.6 Ji, T. and Ellis, B.R.: Effective bracing systems for temporary grandstands. *The Structural Engineer*, 75 (6), 18 March 1997, pp95-100
- 9.7 Department of National Heritage and Scottish Office. *Guide to safety at sports grounds.* 4th ed. London: The Stationery Office, 1997
- 9.8 *BS EN 13200-1: 2003: Spectator Facilities. Layout Criteria for Spectator Viewing Area. Specification.* London: BSI, 2004
- 9.9 *BS EN 13200-3: 2005: Spectator Facilities. Separating Elements. Requirements.* London: BSI, 2006
- 9.10 *BS EN 13200-6: 2006: Spectator Facilities. Demountable (temporary) stands.* London: BSI, 2006
- 9.11 *BS EN 1991-1-1: 2002: Eurocode 1: Actions on Structures. General actions. Densities, self-weight, imposed loads for buildings.* London: BSI, 2002
- 9.12 *BS 648: 1964: Schedule of weights of building materials.* London: BSI, 1964
- 9.13 Littler, J.D. *Temporary demountable grandstands: dynamic response.* Garston: BRE, 2000 (BRE IP3/00)
- 9.14 Ellis, B.R. and Ji, T. *The response of structures to dynamic crowd loads.* Garston: BRE, 2004 (BRE Digest 426)
- 9.15 *BS 1139-2-1: 1991: Metal scaffolding. Couplers. Specification for steel couplers, loose spigots and base-plates for use in working scaffolds and falsework made of steel tubes.* London: BSI, 1991
- 9.16 *BS 5588-6: 1991: Fire precautions in the design, construction and use of buildings. Code of practice for places of assembly.* London: BSI, 1991
- 9.17 *BS 6180: 1999: Barriers in and about buildings. Code of Practice.* London: BSI, 1999
- 9.18 *The Disability Discrimination Act 2005: Chapter 13.* London: The Stationery Office, 2005
- 9.19 *BS 8300: 2001: The Design of buildings and their approaches to meet the needs of disabled people. Code of practice.* London: BSI, 2001
- 9.20 Office of the Deputy Prime Minister. *Building Regulations 2000. Approved Document M: Access to and use of buildings.* 2004 ed. London: NBS, 2006
- 9.21 Scottish Building Standards Agency. *The Scottish building standards technical handbook: non-domestic.* [s.l.]: The Stationery Office, 2007 [Section 4: safety]
- 9.22 Northern Ireland Department of Finance and Personnel. *Building Regulations (Northern Ireland) 2000: Technical Booklet R: Access to and use of buildings* [2006 ed]. [s.l.]: The Stationery Office, 2006
- 9.23 The Football Stadia Improvement Fund and The Football Licensing Authority. *Accessible stadia.* London: The Football Stadia Improvement Fund and The Football Licensing Authority, 2003 (Sports Grounds and Stadia Guide No 1 (SGSG1))

SECTION 10
STAGES AND SIMILAR STRUCTURES

This Section is intended particularly for designers, inspectors and suppliers of stage structures

“Temporary stages should be assembled in accordance with engineering documentation that comprises drawings, calculations and specifications all prepared by a competent person. Engineering documentation should be independently checked by a chartered engineer.”

“Design of any temporary staging system is essentially a consideration of the balance between weight, strength, fabrication cost and deployment cost of the individual components. In such a consideration, safety must not be compromised.”

“Lack of handrails and poor stairs are the biggest causes of stage-related accidents indoors.”

“For stages that rely on ‘Wind management’ techniques, the presence of competent personnel on site to deal with the requirements of the ‘Wind management plan’ is critical.”

10 STAGES AND SIMILAR STRUCTURES

10.1 Introduction

This Section gives guidance on the design and erection of temporary stages for concerts and similar events. These structures differ from those discussed elsewhere in this *Guide* in that they are not for use by the public.

Stages typically have the following features:

- A platform used by performers raised above ground level to give an audience a better view of a performer/performers.
- Weather protection for outdoor locations.
- A support structure for lifting equipment.
- They are a workplace.

Large numbers of temporary indoor stages are in daily use for leisure and educational purposes, supplied by a wide range of manufacturers. Many indoor stages are purchased outright and assembled on a repetitive basis by the purchaser.

By contrast, there are far fewer outdoor stages and consequently far fewer suppliers. Outdoor stages need to meet all the requirements of indoor stages plus the additional factors created by the effects of the weather: wind; rain and temperature extremes; and problems from overloading, abuse and lack of maintenance (see Section 7). Outdoor stages are typically hired as required and erected by the supply contractor.

Ancillary special structures, such as those for supporting lighting equipment, video screens and loudspeakers, are discussed separately in Section 13.

At the time of publication of the Second Edition, several stage contractors used a 'wall' of scaffolding to each side of the stage floor, with a roof system suspended between the two walls. This type of structure has been seldom used in the UK in recent years and therefore the problems peculiar to this design are not covered in this edition. This design is still in widespread use in other parts of the world.

Whilst there are many different proprietary systems available to create stage structures, they can virtually all be categorized into one of the following types.

- Stage floor platforms and associated sub-structures.
- Free standing roof systems.
- Roof systems that are supported on a stage floor.
- Roof systems that are supported within the sub-structure of a stage floor.
- Fully integrated units that are typically vehicle based ('Mobile stages').

There are many similarities between stages designed for use indoors and outdoors. 'Indoors' is defined as any space in which a temporary stage is erected where it is protected from the effects of the weather. This includes inside marquees and circus tents, for example. Structures used indoors are generally stage platforms with associated access ramps and stairs. Many of these use 'ground-support' frames to create suspension facilities for loads, typically lights, sound equipment and video screens. These are structurally similar to outdoor stage roof structures without the weatherproof covers. With the obvious exception of wind loads, the engineering issues are largely identical between indoor and outdoor stage structures.

10.2 General design requirements

10.2.1 Introduction

Design of any temporary staging system is essentially a consideration of the balance between weight, strength, fabrication cost and deployment cost of the individual components. In such a consideration, safety must not be compromised. Design should start from the premise that an appropriate level of safety will be provided. The robustness of the structure should also be considered. Some elements of the design will be more critical than others and some components (or connections between components) will require particularly careful checking each time the structure is erected. Details of items critical to each 'stage type' are detailed later.

Physical checking of temporary stages is much simpler and more effective if the designer's statement is available to the Enforcing Authority and other parties.

10.2.2 Calculations

Temporary stages should be assembled in accordance with engineering documentation that comprises drawings, calculations and specifications all prepared by a competent person. Engineering documentation should be independently checked by a chartered engineer. This may be someone from the same organisation as the designer if it can be demonstrated that the checking is genuinely independent. The results of the check should be included with the technical documentation applicable to the stage.

Of the calculations that are applicable to all temporary demountable structures (Section 5.1.4) the following are particularly required for stage structures:

- Ability of stage surface to support the design loads and other given criteria.

- Ability of superstructure to support the weight of any suspended equipment, including details of permissible support methods to suspend the equipment.
- Ability of the whole structure to resist all imposed forces on it including those created by weather conditions.
- Ability of the structure to resist the additional wind loading on the suspended equipment.
- Interaction between coupled elements (i.e. junctions between floors and roof systems etc.).

Requirements for providing information to Enforcing Authorities are discussed in Sections 4 and 5.1.3.

10.3 Stage types

10.3.1 Stage floor platforms and associated sub-structures

Stage surfaces have to withstand static loads, such as the weight of stage sets and equipment, and dynamic loads caused by people dancing, jumping, etc. To ensure that these two conditions are fully considered the surface should be designed to withstand a minimum vertical static equivalent load of 5kN/m^2 and a simultaneous notional load commensurate with the use (see Table 12) applied in any one horizontal direction at the stage surface.

The loading applies to all the areas associated with the stage including wings, the performance area and extension platforms, rostra and stage sets and the operating limit clearly defined in the engineering documents.

Assuming that the self weight of the rostra and stage sets does not exceed 2.5kN/m^2 , the design vertical static equivalent load on rostra and stage sets should generally be 2.5kN/m^2 , unless defined otherwise in the engineering documentation. Appropriate risk assessments should be prepared for the rostra and stage sets and the operating limits clearly defined in the engineering documentation.

Stage floor surfaces should be constructed in such a way as to remove any tripping or undesirable slipping hazards. It is recommended that stages should be designed to carry a point load of 3.6kN over an area $50 \times 50\text{mm}$ without causing any damage to the floor and without causing excessive deflection of the floor panels (e.g. deflection of more than 10mm relative to the adjoining panels).

If any of the risk assessments carried out for the event indicates the potential for higher static or dynamic loading to occur, this should be dealt with on a one-off basis specific to the event. The event



Figure 23 A typical rectangular stage system

organiser, Enforcing Authority and other relevant parties should then be informed in writing (see Section 5.2.3) by the contractor as to how the higher loading requirement has been met.

Stage floor platforms are usually built either of system scaffolding or of one of the many proprietary systems. Figure 23 shows a typical rectangular stage system.

Proprietary systems always have a method of linking the sections together. Many systems rely on simple bolts between sections and use cut lengths of scaffold tube to provide variable height legs. Care should be taken to ensure that enough bolts are used to join the sections together, the required quantity being specified by the designer. It is not acceptable to join adjacent legs with PVC tape, plastic cable ties or other non-structural components.

Products from different manufacturers should not be mixed, even if they appear to be similar, unless the implications have been fully considered by a competent person.

Systems with scaffold tube legs will require diagonal bracing to bring the horizontal loads down to ground if the sections are used above a particular height. This height is a critical value which should be specified by the designer in relation to the material from which the scaffold tubes are made. For typical staging modules which are $2.4 \times 1.2\text{m}$ in plan, using scaffold-grade tubes as unbraced legs, maximum deck heights of 0.9m for aluminium tubes and 1.2m for steel tubes are recommended provided that there is a moment connection at the top of each leg.

These figures are for guidance only. The allowable height depends on the diameter and thickness of the

tube, the axial load and the lateral sway load. The design of the leg should be proven by calculation. For stages built of multiple modules bolted together, it is imperative that each module has its full complement of legs. In cases where a single tube is used to support the corner of more than one deck panel, specific calculations to show the suitability of the tube and the effect on the resistance to bending of the deck panel should be provided. Aluminium and steel tubes should preferably not be mixed in the same structure. However, the use of aluminium/steel hybrid structures is increasing, and care should be taken in the selection of design parameters if the two materials are deliberately used together in the same structure.

Many of these systems appear to be very simple but calculations should still be provided for them and they should still be subject to the same enforcement action as more complex structures.

10.3.2 Roofs

Roofs (and indoor grids) should be designed to support the imposed loads as well as the self-weight of the structure (Figure 24). Imposed loads may include working personnel, loads created by wind and snow, suspended sound, lighting and video equipment and by anchorages for moving equipment.

The complete roof, individual components and fixings of the coverings should be capable of resisting any uplift forces caused by the maximum design wind load.

Certain wind conditions cause uplift and/or overturning on most stage structures. The designer should clearly show the extent of these forces and specify how they are to be dealt with. If kentledge is the chosen option, details should be given of how this is to be attached to the structure. Consideration should be given to the coefficient of friction between the kentledge and the ground.

Calculations of the uplift forces along the eaves and gable, carried out at the design stage, should show that the fixings for the roof coverings are able to withstand these forces.

Roofs which are supported on masts may impart a bending moment to the mast due to deflection in the roof depending on the lack of fit of the connection of the roof grid and the mast and the relative stiffness of the two. The designer should clearly show the extent of these bending moments and show how they are to be resisted.

Roofs that are supported on masts are at risk of total collapse in the event of a single failure of a mast, chain hoist or lock off mechanism. Methods of avoiding any such failure should be considered in the



Figure 24 A typical curved roof stage system

engineering documentation and the risk assessments for the event.

Where stability of the roof structure is provided by the use of external guy ropes, particular care should be taken with the positioning of the guy ropes and the method of anchorage.

Where a failure of the structure could cause injury, roofed outdoor structures should be monitored by a competent person at all times. In practice this means that a representative of the stage supplier should be on-site at all times, particularly when the stage is in use by workers or during a performance. For stages that rely on 'Wind management' techniques described in Section 8.1.3.2 Option (b), the presence of competent personnel on site to deal with the requirements of the 'Wind management plan' is critical.

Fabric and other sheeting materials used to cover roofs and create walls need to be able to deal with the imposed wind forces, fail safely if dislodged by the wind, and be flame retardant.

10.3.3 Free standing roof systems

All current known designs require kentledge to resist wind uplift (and/or overturning – see Figure 25) and the method of attaching the kentledge to the structure should be clearly detailed in the engineering documentation.

The ability of the roof masts/towers to resist bending forces associated with lateral loads should be carefully considered in the engineering documentation for roof systems with no external guying.

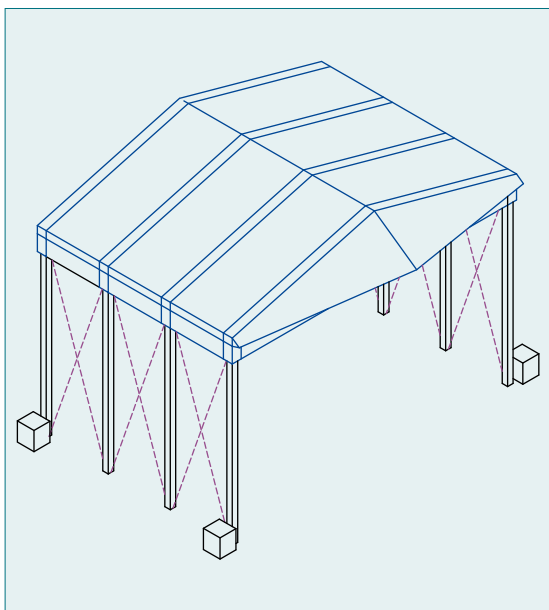

Figure 25 A free standing roof system

10.3.4 Roof systems that are supported on a stage floor

The majority of 'typical' medium size stages in use in the UK fall into this category (Figure 26). In addition to the usual calculations, specific details are required to show how the stage floor surface is designed to resist the downward forces from the roof structure (usually by some form of counter or under-propping), the upward forces due to wind forces (usually requiring kentledge), plus any lateral forces due to the roof shape. All these forces and actions should be considered in the engineering documentation.

10.3.5 Roof systems supported within the sub-structure of a stage floor

This is an increasingly common technique, (see Figure 27) currently found mainly in the larger structures available. The key advantages are:

- The stage sub-structure levelling system provides a level surface for the roof supports.
- Some of the self-weight of the stage sub-structure and decking can be used to replace some or all of the kentledge required to resist uplift.

In addition to the loads associated with the stage floor, specific calculations and details should be provided in the engineering documentation to show how the various forces from the roof structure are dealt with by the sub-structure.

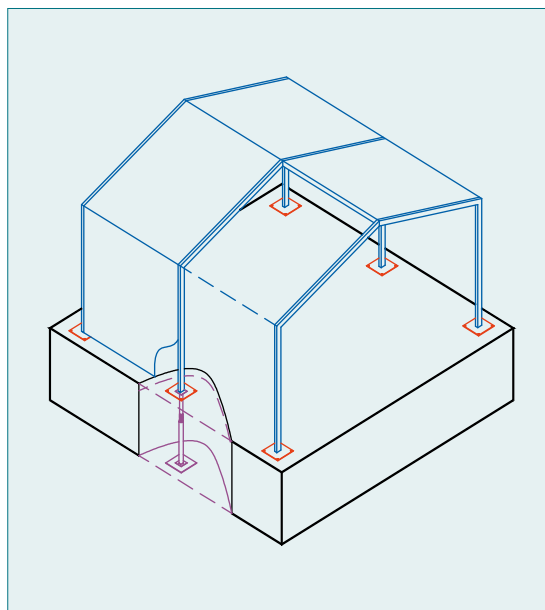

Figure 26 A roof system supported on a stage floor

10.3.6 Fully integrated units that are typically vehicle based

Since the publication of the Second Edition of Temporary demountable structures, the use of vehicle based stages (usually known as Mobile Stages) has become much more widespread (see Figure 28). Generally they are easy to manage and to check for safety as there are so few loose parts. However, they should comply with the same requirements for floor loading and resistance to wind as any stage and engineering documentation should be available to verify this.

The event organiser and Enforcing Authority should review the engineering documentation for compliance with both this guidance and relevant British Standards prior to hiring and/or use.

10.4 Access and egress for non-public use

Stages should be provided with adequate access by means of ramps and/or stairways (see Figure 29). It is good practice to have at least two means of access/egress.

It is recommended that all stairs used for general stage access/egress should comply with the Building Regulations^{10.1}.

Guidance on the minimum size of tread and maximum size of riser for stairways used for single person access to work platforms is given in BS EN 1004:2004^{10.2}.

Ramps for equipment access to stages often terminate at the bottom on a truck 'dock'. Designers need to consider the probability of heavy vehicles reversing into the dock structure. Docks should also have a staircase to facilitate access and egress of crew.

The gradient of any ramp should be gradual enough to enable equipment to be moved safely. Specific safety measures will be required if the gradient is steeper than 1:5. Ramps should, if possible, be no longer than 8m between horizontal landing areas. Landing areas should be at least 1m in length in the direction of travel and at least as wide as the access way/ramp. Ramps that are to be used to provide access to a stage for unassisted wheelchair users should have an absolute maximum gradient of 1:12. For an individual flight of 5m the maximum gradient is 1:15^{10.3,10.4,10.5}.

The surface of ramps and treads, particularly those which could become wet, should be covered with a slip-resistant material.

Adequate handrails should be provided to all ramps and stairways. Ramps should have suitable rails to restrain equipment on wheels.

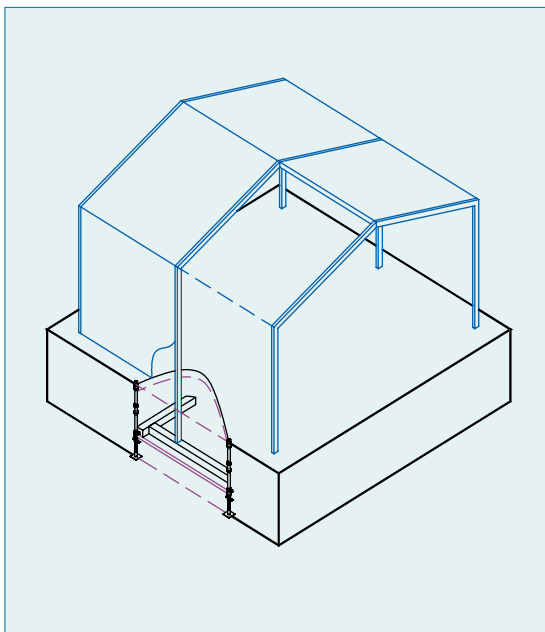

Figure 27 A roof system supported within the stage floor substructure

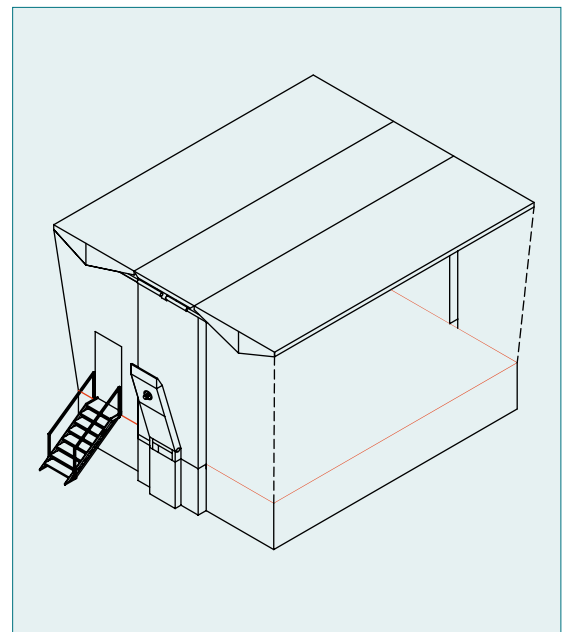

Figure 28 A mobile stage

10.5 Protection against falling

The Work at Height Regulations^{10.6} require all contractors to take suitable measures to prevent risk of falling during the assembly and removal process. These measures should be fully documented in accordance with the requirements of the regulations.

The liability for preventing falls of other personnel transfers to the client when the completion certificate is issued. (See Section 5.2.6).

Handrails should be provided to all edges of a stage, except the edge facing the audience, whenever possible. BS EN 12810-1:2003^{10.7} gives two loading criteria for handrails used in work areas only, such as stages and access platforms, where the loads are applied in the most severe location:

- A limiting deflection of 35mm under a 0.3kN point load applied horizontally; and
- No breaking or deflection more than 300mm at any point under a 1.25kN point load applied vertically.

The client needs to agree measures with the stage supplier to assist in preventing falls to technicians installing equipment (typically sound, lighting and video) on the finished stage. Temporary barriers may be needed to the front edge of the stage during non-show times.

Lack of handrails and poor stairs are the biggest causes of stage-related accidents indoors. There should be a handrail on all except the performance edge(s) of all stages, regardless of height and at every staircase.

Indoor stages are often built in the same place repeatedly and at the start of an event the light level can change abruptly from full on to total blackout almost instantly. A combination of familiarity and temporary blindness has caused many accidents. Adequate handrails and clear marking of edges are essential to prevent these.

Serious accidents have occurred on stages with a narrow gap to an adjacent wall where people have stepped into the gap and become wedged in. If narrow gaps cannot be avoided they should be protected by handrails.

As it is currently unacceptable to most performers to appear behind a handrail, specific measures to protect performers against falling off the front of the stage are required. It has to be appreciated that performers face into very powerful lights, which may dim or go to 'blackout' very suddenly, leaving them temporarily unable to see edge markers.

Measures in regular use include providing:

- A lower 'ledge' below stage floor height. This is particularly suited to high stage floors and may double as a location for sound and lighting equipment.

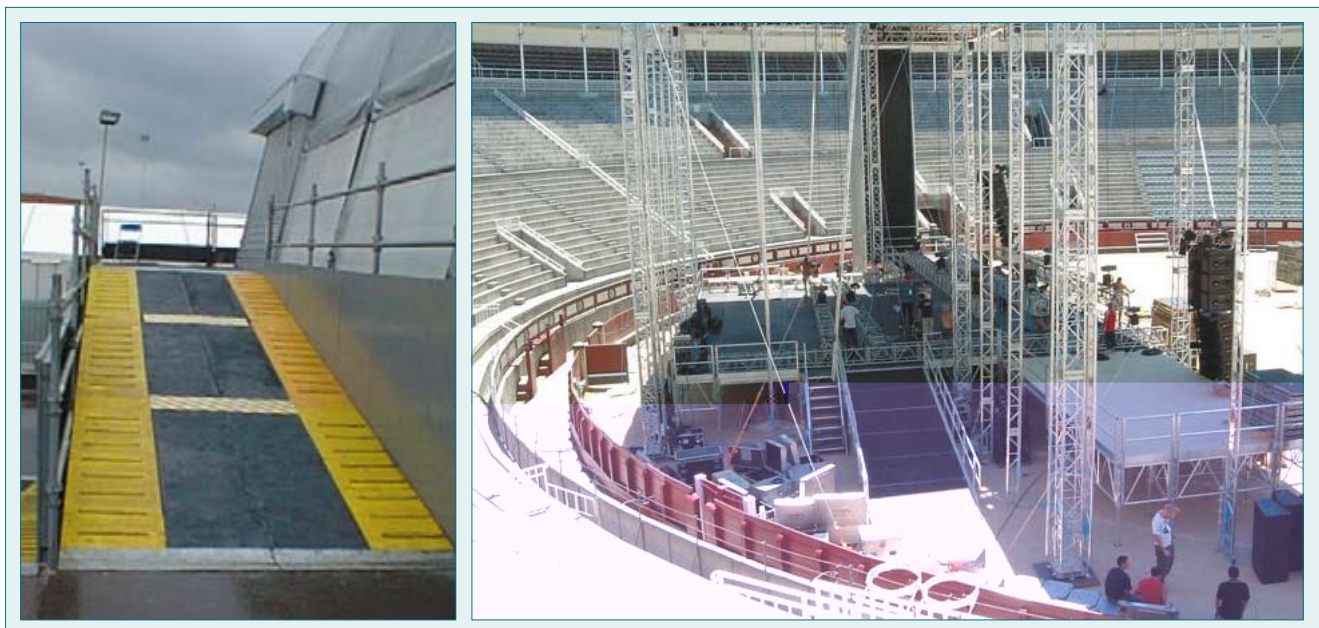

Figure 29 Ramp/dock arrangements

- A tactile strip that provides warning of approach to the edge.
- A slight upstand to the front edge.

In any event, the front edge of stages, physical obstructions and stair edges should be marked with white or luminous tape. For best visibility, white tape should be at least 50mm wide.

10.6 Use of lifting equipment in the construction and use of stages

The Lifting Operations and Lifting Equipment Regulations^{10.8} (LOLER) apply in all premises and work situations subject to the Health and Safety at Work, etc. Act^{10.9}. They require companies using lifting equipment to carry out suitable inspections and to manage lifting operations safely. Reference should be made to the Approved Code of Practice on the regulations^{10.10}.

When sections of structures (typically stage roofs) are being lifted by multiple hoists adequate provision should be made so that if a hoist fails, the structure will not fall to the ground. One way of achieving this is to use enough hoists or winches so that if one fails the others will safely support the structure being lifted.

A detailed method statement and risk assessment should be prepared to cover the raising and lowering procedures of a roof structure. In particular, the positioning of personnel required to monitor and control the movement should be carefully considered. Non-essential personnel should not be in the immediate and surrounding area of the roof structure during raising and lowering.

When any hoist-lifted roof is in use, each hoist should have a mechanical safety device (lock-off) to prevent roof movement in the event of hoist failure.

Care should be taken that multiple hoists provide an even lift and that adjustments to the hoisting process can be made to achieve this.

Many stage roofs are used to suspend equipment such as sound and lighting. As such, there is a mandatory requirement that every component is subject to an inspection regime by a competent person and that the associated documentation is made available to anyone who uses the equipment to suspend loads^{10.8, 10.11}.

Particular care must be given to the methods used for fixing suspended objects to a suspended structure. Attention to detail is important and heavy objects should have at least two fixings, either one of which will prevent the object from falling. Falling fittings

such as nuts and bolts are a hazard and it is good practice to make regular checks for loose components. Vibration can promote loosening so structures subject to vibration from speakers, wind, or other sources, need careful consideration.

10.7 References

Readers are advised to check for updates given to references throughout this document.

- 10.1 Office of the Deputy Prime Minister. *The Building Regulations 2000. Approved Document K: Protection from falling, collision and impact*. 1998 ed. incorporating 2000 amendments. London: NBS, 2006
- 10.2 *BS EN 1004: 2004: Mobile access and working towers made of prefabricated elements. Materials, dimensions, design loads, safety and performance requirements*. London: BSI, 2005
- 10.3 Office of the Deputy Prime Minister. *The Building Regulations 2000. Approved Document M: Access to and use of buildings*. 2004 ed. London: NBS, 2006
- 10.4 Scottish Building Standards Agency. *The Scottish building standards technical handbook: non-domestic*. [s.l.]: The Stationery Office, 2007 [Section 4: safety]
- 10.5 Northern Ireland Department of Finance and Personnel. *Building Regulations (Northern Ireland) 2000: Technical Booklet H: Stairs, ramps, guarding and protection from impact*. [2006 ed.]. [s.l.]: The Stationery Office, 2006
- 10.6 *The Work at Height Regulations 2005*. London: The Stationery Office, 2005 (SI 2005/735)
- 10.7 *BS EN 12810-1: 2003: Façade scaffolds made of prefabricated components. Product specifications*. London: BSI, 2004
- 10.8 *The Lifting operations and lifting equipment regulations 1998*. London: HMSO, 1998 (SI 1998/2307)
- 10.9 *Health and Safety at Work etc. Act 1974: Chapter 37*. London: HMSO, 1974
- 10.10 Health and Safety Commission. *Safe use of lifting equipment. Lifting operations and lifting equipment regulations 1998: approved code of practice and guidance*. Sudbury: HSE Books, 1998 (L113)
- 10.11 *The Provision and Use of Work Equipment Regulations 1998*. London: HMSO, 1998 (SI 1998/2306)

SECTION 11
BARRIERS FOR EVENTS

“The area directly in front of the stage barrier is likely to be the most critical.”

“The front-of-stage barrier is the first line of defence for the audience, vital to allow pit stewards to carry out their duties.”

11 BARRIERS FOR EVENTS

11.1 Introduction

Various different types of fences or barriers are used for concerts, events and the like. This Section concentrates on the Front-of-Stage barriers but it is useful to describe the different types of fence or barriers used, their potential strengths and therefore their appropriate usages.

Pedestrian barrier, Police barrier, or Royal barrier are terms used for steel frame barriers used extensively for street events such as parades and street races where there is a need to very quickly deploy large lengths of barrier to keep the crowd separate from the parade or the runners, etc. These are usually 1.1m high and come in various lengths from 1.5m to 3.5m and can be held in large stacks ready for easy deployment. They are free standing, supported on flat or arched feet at either end, or there is a version with a horizontal hooped base running the full length (see Figure 30). These barriers are useful where there is no crowd pressure involved. They are used purely to define ‘no go’ areas for the public. They have little structural strength to resist crowds.

Mesh panel fencing consists of a tubular steel frame with an infill of steel wire mesh, typically 3.5m long by 2m high supported by insertion of the end uprights into separate block units which may be concrete or heavy plastic (Figure 31). The blocks have various holes to allow end fixing or middle fixing. These fences are extensively used around event sites during build periods, where fence lines have to be opened quickly or where the site boundary may be changing rapidly. These systems have no structural strength to resist crowds and usually require diagonal braces or struts at right angles to resist wind loading in situations where signs or other covering reduces the permeability of the panels. An anti-climb version is available that reduces the spacing of the vertical elements of the infill mesh.

Hoarding is the general description applied by the events industry to panels similar to the mesh panels described above, with two clear differences. The mesh infill is replaced by a solid steel infill (thin and usually corrugated to resist bending) and the panel width is reduced to 2m, due to the extra weight (Figure 32). Systems are currently available in heights of 2.0m and 2.4m. Due to the impermeability of the infill, these systems have to use rakers at every panel join, which are anchored by ground pins or kentledge units. Even with all the rakers in place, these systems have limited resistance to lateral loads such as wind loads or crowd



Figure 30 Assorted barriers (arch foot, flat foot and hooped base)



Figure 31 Mesh Panel fencing



Figure 32 Hoarding

pressure. The exact support arrangements as specified by the manufacturer must be closely followed to achieve the stated capacity. Also care must be taken to ensure that props or struts, etc are not removed.

It should be noted that this system should not be confused with Hoarding as used by the construction industry, which is usually built in-situ from plywood covering a stout timber frame set into concrete.

Steel Panel systems (see Figure 33) are widely used as the perimeter enclosure for events where there is a wish to control admission and offer a fairly high degree of security. They are formed from a plastic coated flat steel sheet covering on a fabricated steel frame. The frames are bolted together and overlap and are secured to the ground. Typical panel size is 3m high \times 2.4m wide. There are several copies of the original design on the market that appear not to meet the original design specification, which is to withstand 25m/s wind gusts and to resist crowd pressure of 1.25kN/m applied at 1.5m (shoulder height) above ground. An essential safety feature is the bolt connections between panels, lapped to prevent any gaps. Rakers at every join are essential at the base of the panel frame. This enables a substantial length of fence to operate in tension along the length of the fence in the event of a localised failure (on the same principle as motorway crash barriers). Missing bolts negate this feature.

Roadway Panel systems (Figure 34) are used as the 'ultimate' fence system, offering very high loadings (resistant even to vehicle impacts if installed correctly). The panel sizes are similar to the Steel Panel system described above. Interconnection between panels is usually by an H profile sleeve that locates the edges of two adjacent panels. Heavy duty rakers and extensive ground pinning are essential due to the self weight of the panels and the potential applied loadings.

Front-of-stage barriers have considerable structural strength and should be designed to resist the highest loadings applied by crowds. They are used at the front of the viewing areas where large crowds are in attendance. There are a number of different systems but they are generally heavily constructed barriers in 1m sections constructed of steel or aluminium and specifically designed for purpose. The usual format is an 'A' frame with built in steps for the stewards to be able to get up and reach into the crowd. These barriers rely on the weight of the crowd on a footplate at the front to maintain stability. They are designed to travel flat and to be erected on the site for the event.

To fulfil their purpose they must be erected and connected together strictly in accordance with the manufacturers' specification.



Figure 33 Steel Panel fencing



Figure 34 Roadway panel fencing

Front-of-stage barriers (Figure 35) are essential elements in crowd safety management. *The Event Safety Guide: Guide to Health, Safety and Welfare at Music and similar events*^{11.1} states that ‘If audience pressure is expected a front-of-stage barrier will be necessary’. These barriers are vital tools in the safety management of any events where crowd pressure is a hazard.

In order to determine the appropriate arrangements for front-of-stage barriers it is essential that a full risk assessment is carried out to determine the range and nature of the people who will be attending the event, their likely level of excitement, and possible intoxication and to assess what their normal behaviour will be together with their reaction to incidents which might occur.

A barrier (also referred to as a guard in the Building Regulations and as a Separating Element in international standards) is a structural element intended to prevent people from falling, and to retain, stop or guide people. A front-of-stage barrier creates a sterile area or sterile corridor enabling safe management practices that provide an acceptable level of safety in this critical area.

The area directly in front of the stage barrier is likely to be the most critical. Crowd densities here may be very high. Crowd surges may be experienced, and subsequent dynamic loads on barriers at the front of the stage may be considerable. Fortunately, such surges and loads are generally of short duration. Experience and research suggest that the greatest dangers are not large transient pressures on people, but crowd collapse and subsequent traumatic asphyxiation.

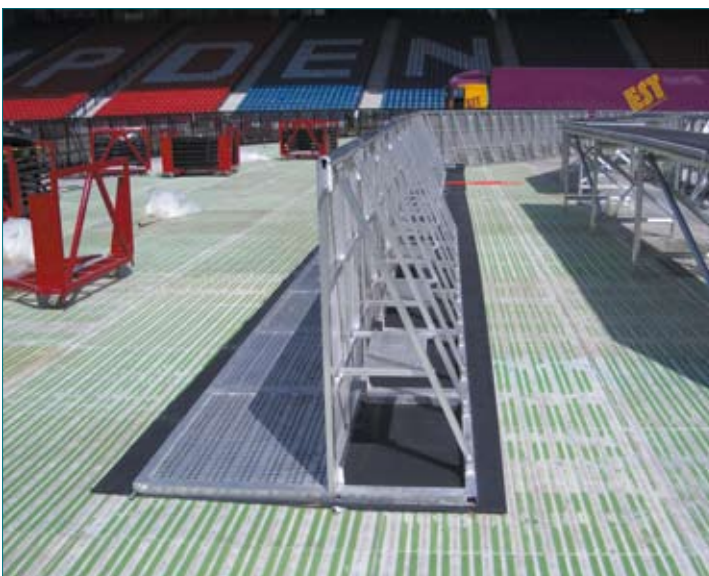

Figure 35 A Front-of-stage barrier

Crowd pressures can reach undesirable levels and individual behaviour can place innocent parties at risk. The function of the barrier is to stand firm thus preventing dangerous crowd movement, which could cause collapses, to provide the ability for stewards to monitor the crowd and assist people who may be approaching, or are in distress as a result of crowd pressures. The front-of-stage barrier provides a platform for the stewards giving them the height to allow them to spot people in need of assistance and more easily pull them from the crowd into the pit area where they can be escorted out or taken for medical treatment.

Demountable barriers function by using the dead load of the crowd on the footplate to provide the mass to resist overturning and sliding. In order to function correctly front-of-stage barriers should not slide, overturn, lift or collapse. It is often suggested that a degree of sliding of a barrier will relieve pressure in the crowd. There is no sound argument for this proposition. There is currently no way to control the movement of a barrier or to predict when it will stop. The barrier is likely to sustain damage in the process, risk crowd collapse and create dangers for people working in the pit.

The possibility of lifting of barriers is also a consideration where ‘finger’ barriers are used in order to reduce lateral movement of the crowd. Barriers should be designed to resist any lifting as a result of pressure from both sides.

Multiple barrier systems may introduce a measure of control on the crowd density in the area immediately in front of the stage but every barrier layout carries its own set of hazards. Finger barriers create corners where people could be trapped. Multiple barrier systems where a second or even more lines of barriers are placed further back into the crowd may help to control the pressures in the immediate front of stage area but these further barriers have to be manned in terms of stewards and medical assistance and issues such as loading of the crowd, density and ingress/egress, means of escape, all have to be considered.

A seated audience does not automatically negate the need for a front-of-stage barrier, particularly in temporary venues or in a venue designed for a specific purpose that differs from the nature of the event being held.

The gradient and condition of the ground towards the stage should be considered in the risk assessment. Particular attention should be given to step changes, such as kerb lines, which run across the line of the front of the stage barrier. Given the reliance on frictional resistance created by the weight of the

crowd any areas where the barrier may require to be packed up to accommodate a change in level should receive careful consideration and must be kept away from the areas where the highest crowd pressures are most likely to occur.

11.2 Design

The layout and arrangement of the front-of-stage barrier is a function of stage height, side-stage positions, stewarding arrangements and the venue geometry. Reference should be made to the *Guide to Safety at Sports Grounds*^{11.2}. Various types of barrier are currently in use in the entertainment industry, including purpose-built modular units.

Where barriers are connected to the stage or its components the design of the stage should take account of the barrier loading.

Barriers constructed from scaffolding components are not recommended.

A front-of-stage barrier can be subjected to very substantial crowd pressures. The pressures are applied to the barrier through the individuals at the front of the crowd.

Figure 36 illustrates graphically how spectators can be crushed against front-of-stage barriers, leading to the risk of asphyxiation or localised injury to the chest region. As noted earlier, crowd management is vital for safety.

Figures 36 and 37 illustrate how the heights of individuals in a crowd vary considerably across a wide range. Generally, a vertical flat surface provides effective protection across a range of individual heights. It is recommended that the maximum height of such a barrier should be between 1.05 and 1.22m.

The barrier should not have sharp edges, gaps or other prominent elements that could cause injury. Custom-designed padding can help to reduce risk of injury but it may be harder for stewards to extract distressed spectators from such padded barriers.

The width of the barrier will be defined by the width of the stage. Where necessary the front-of-stage barrier should be transformed outside these limits into a sightline obstruction barrier of minimum height 2.4m. The general principle should be to achieve the widest possible sightline in an arc from stage right to stage left. If this is provided, a comfortable and safe crowd shape is created. Fans will not need to crush to the front or stage centre to obtain a satisfactory view.

Although in many cases, and for smaller venues, straight barriers have been the norm, convex curvature of the barrier in plan relative to the audience may be beneficial in reducing crowd density.



Figure 36 Crowd pressing onto front-of-stage barrier



Figure 37 Front-of-stage barrier used at right-angles to the stage

The sterile area between the stage and the front-of-stage barrier should be provided with a step or preferably a continuous platform immediately to the rear of the barrier that:

- Enables security and rescue services to overview the crowd, and
- Reduces the risk to stewards when lifting and extracting distressed individuals from the audience.

A continuous non-slip platform is particularly advantageous at outside venues where:

- The ground may create difficult working conditions, or
- A volatile or large audience is likely to result in significant numbers of spectators requiring assistance.

The dimensions of the sterile area or corridor will depend on the width of the stage, operational requirements for stewards and medical staff and the anticipated degree of activity as a result of the profile of event.

Short barrier panels with no footplates are sometimes used to permit bends in the line of the barrier to allow the required configuration to be achieved. These are shorter than the standard barrier section and having no footplate rely totally on load transfer to adjacent sections equipped with footplates and their use should be carefully considered. These panels should be clearly identified on the drawings so that their numbers and location can be assessed. Their use should be minimised, they should be kept away from highly pressured areas where possible and they should be spaced out with the largest possible lengths of standard barrier in between.

Gates in barriers, whether opening away from or into the pit, would not be able to be operated or could not be utilised safely when the barrier is subject to any crowd pressure. These gates again rely on adjacent standard sections to carry their loading but to a greater extent than the short panels referred to above and this therefore weakens the overall barrier configuration. Their use should generally be avoided.

11.2.1 Design loading

Either permissible stress or limit state design procedures may be used, according to the recommended procedure given in the British Standard appropriate for the material to be used, treating the loads given in BS EN 1991-1-1:2002^{11.3} as working loads for permissible stress design, or characteristic loads for limit state design.

When using limit state design, the partial safety factors for loads and materials should be those recommended by the appropriate British Standard for the relevant material. The strength of the barrier should be designed as ultimate limit state (ULS).

The characteristic imposed loading for a front-of-stage barrier is a horizontal loading of 3kN/m applied at either a height of 1.1m or the height of the barrier where this exceeds 1.1m. The characteristic loading is used in conjunction with a partial factor that is associated with the uncertainty of the action, in this case overall stability against overturning and sliding.

The minimum factor for stability against overturning and sliding should be 1.5. Therefore the design loading is $3 \times 1.5 = 4.5\text{kN/m}$.

Where a footplate is integral with the barrier the weight of the people may be considered to act as kentledge in resisting overturning and in creating



Figure 38 Audience profile of predominantly teenagers and under with some parents in attendance

frictional resistance. However, care should be taken regarding the realism of assumptions made in terms of the number of people required to be packed onto the footplate to generate the required dead load. For example at events where predominately young audiences are involved (Figure 38) the average weight may be at considerable variance from the assumed standard weight of a person. Calculations have indicated assumed densities at the barrier of the order of 12 people per square metre. The crowd will be at its most dense at the barrier but, it is worth noting that this is equivalent to 0.08m^2 / person compared to the average figure of 0.5m^2 /person i.e. 2 people per square metre, suggested by the *Guide to Safety at Sports Grounds*^{11.2}.

The area of the footplate and the coefficient of friction between footplate and foundation are the critical components in assessing a barrier's resistance against sliding. Coefficients of friction vary and this factor should be considered in the barrier risk assessment. Placing a suitable sheet material to increase frictional resistance or mechanical fixing of the barrier may be essential. Some barrier suppliers recommend the use of rubber matting below the footplate on surfaces such as plastic pitch coverings, asphalt or concrete: the properties of the rubber matting may not be fully defined.

Some calculations assume a degree of load shedding or sharing from overstressed barrier sections to adjacent sections, however this could only be effective if the extent of the fully loaded or overstressed sections was extremely localised. (See also comments above referring to panels without footplates and gates in barriers.) Pressure over a wider front would mean that the load would be passed onto an already overloaded section of barrier, which was already looking to shed some of its load. Surge events can act like a wave spreading out from a point some distance back from the front-of-stage barrier that arrives at the barrier across a wide front.

11.3 Hoarding or fences outwith the main viewing areas

Each specific event layout or stage set up must be carefully assessed to determine the likely loads imposed by crowds viewing events and those imposed by crowds in transit. The *Guide to Safety at Sports Grounds*^{11.2} gives guidance on how crowd pressures vary according to the orientation of the barrier involved relative to the crowd movement. Major ingress and egress and emergency egress routes require to be checked.

It is important to manage viewing areas to prevent crowd build-up against obstacles, congestion of exit routes and the potential collapse of fences not specifically designed for crowd loading. Where side-stage fences are to be used to obstruct the sightlines the potential loading on the side-stage fences needs to be assessed.

The characteristic horizontal loading for side-stage barriers that create the sightline obstruction is 1.25 kN/m run of fence. The characteristic loading is used in conjunction with a partial factor that is associated with the uncertainty of the action. In this instance the factor would be 1.5, so the design loading is $1.25 \times 1.5 = 1.875\text{ kN/m}$. This loading should be applied at a height of 1.5m.

In some circumstances it may be appropriate to adopt a lower loading according to the distance away from the viewing area. The first sections might be designed to the above criteria until a point is reached where it is assumed that there will be crowd build up. However, where this area also forms part of the exit route, with the crowd moving parallel to the barrier, then this assumption could not be made. Each specific situation must be carefully assessed and any assumptions made fully recorded.

There have been collapses of free standing masonry walls when subject to crowd pressures and therefore such walls should not form part of an enclosure. Old walls are particularly vulnerable and, due to their weight, can cause serious injury if they fall.

11.4 Site conditions/barrier performance

The load resistance of front-of-stage barriers can vary significantly depending on the characteristics of the surface on which they are standing and this site specific issue requires particular attention. Barrier tests are carried out in controlled conditions, and may be based on assumptions which may not prevail for the real crowd at the actual site under consideration. Sliding is the most likely failure mode and under site conditions barriers may not be able to sustain the required design loading and fail. It is essential that on-site conditions are factored into decisions about barriers, the surface on which they will be required to perform on and the profile of the crowd at the event.

Tests indicate that grass surfaces perform best. However, there are no criteria to define the properties of the grass surface and the ground present at the tests. Even where a surface might be deemed to be

satisfactory when erected on site, conditions may change by the start of an event and are likely to change during events. The provision of water to fans (essential at high energy events) inevitably results in spillage which will soften the ground. In extreme situations the ground can turn to mud with the barrier sliding around in it. Ground protection using geotextile membranes has been used in the high density vicinity of the barrier to protect the ground surface, but care should be taken to avoid introducing slip or trip hazards.

On greenfield sites the pinning of barriers using steel pins into the ground at locations appropriate to the barrier design can enhance the resistance to sliding. Care must be taken not to introduce trip hazards in the pit area. Pinning of barriers in prepared pitches in football stadia and other grounds is not usually appropriate or effective given the prevalence of sand within the make-up and the potential for damage to under soil heating elements, drainage and irrigation systems.

The introduction of proprietary plastic coverings, made up of interconnected tiles or rolls, to protect the pitch in football and other stadia has meant reduced friction coefficients beneath barriers.

Based on tests and calculations some barriers are unable to sustain the maximum design loading and fail by sliding. Further research and development would appear to be called for.

11.5 Multiple barrier arrangements

Multiple barrier arrangements allow zones to be created in which the crowd within a particular zone can be controlled. These are discussed in the *Guide to Safety at Sports Grounds*^{11.2}.

Complex multiple barrier arrangements are now commonplace, tying with elaborate stage sets and often with one or more thrusts. All such arrangements need to be carefully assessed with detailed risk assessments for each section in terms of crowd profile, ingress, egress and emergency escape, loading density, etc. Different makes of barriers should not be used in the same line unless purpose-made connecting pieces are used.

Multiple barrier systems may be more difficult and expensive to construct on open sites and in some cases may not be reasonably practicable. If the means of escape requirements are not considered with great care, multiple barriers can become a system of dangerous pens.

Where multiple barrier systems are installed the arrangements should allow evacuation within a specified time. An analysis should be made of the overall impact upon means of escape when the total population of the arena or site is considered. Zoned barrier arrangements can reduce the incidence of crowd surges and subsequent crushing provided that a comfort capacity calculation is made and satisfactory management practices are in place^{11.4}. An example of a multiple barrier arrangement is illustrated in Figure 39.

Management practices for a multiple barrier system need to recognise that moving a hazard to spectators further from the stage does not remove the hazard. For evening performances stage lighting can be beneficial to stewards manning a barrier immediately in front of the stage. The reduction of lighting levels away from the stage needs to be considered for multiple barrier arrangements.

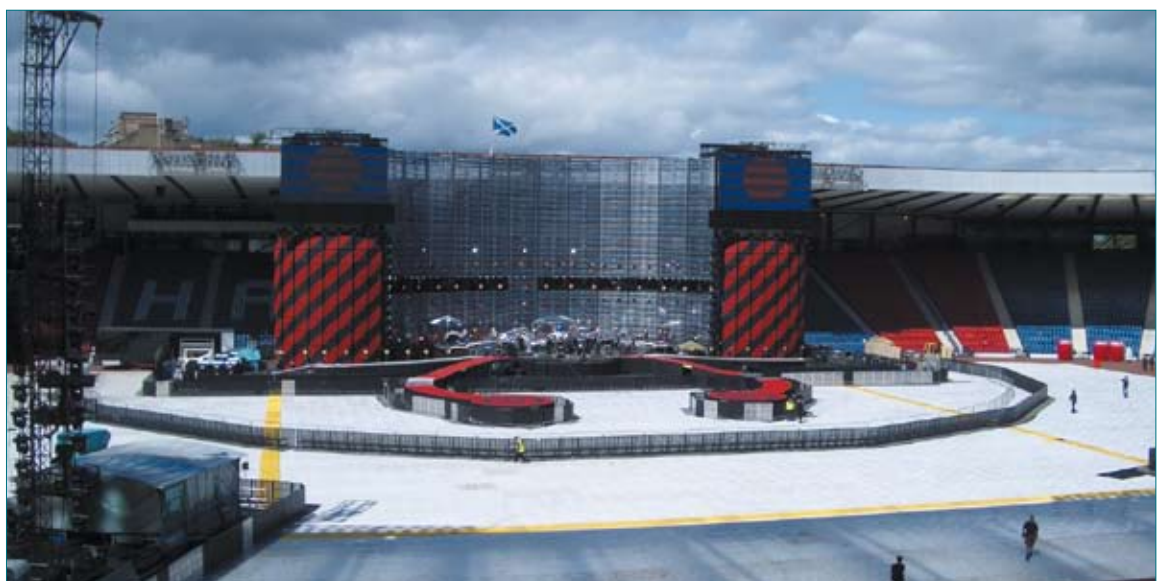

Figure 39 Complex multiple barrier arrangement providing capacity-controlled zones

11.6 Event risk assessment

It is vital that each particular event is comprehensively risk assessed in order to determine the level of pressure likely to be imposed on the barrier. It may be necessary to involve various different disciplines in the exercise.

The following factors need to be taken into consideration.

- The number of people attending the event.
- The type of performance – high profile rock concert, formal civic event, etc.
 - The use of thrusts, ‘B’ stages and any other effects which will affect the crowd response or create crowd movement.
 - The known history of the performers – intelligence gathered from other venues and previous tours.
 - Previous incidents. Factors such as numbers of casualties treated could be indicative of high energy events.
- The crowd profile. Factors affecting how the crowd will respond and how they need to be managed.
 - The range of the ages attending. Mature, broad range mixing adults and children, teens and below (some with parents).
 - The make up of the audience – predominantly male, female or mixed.
- The volatility of the audience. How are the audience likely to behave, standing quietly and clapping at appropriate points or very active prone to pushing forward to get closer to the performers? Elements within a crowd may engage in disruptive activities such as ‘moshing’ which may cause apprehension in audience members, causing them to try to move away from the centre of activity. It has been demonstrated and recorded that extremely volatile crowds can, and do, impose loads in excess of the design loading and where such is anticipated special measures should be taken.
- The proposed barrier layout. Whether a straightforward slightly convex line of barrier across the front of the stage or complex multiple barrier system with potential different densities for different areas within.
- The nature and condition of the site.
 - Grass, firm or soft, prone to flooding or water logging.
 - Hard surface such as asphalt, concrete or gravel.
 - Free of variations in levels or sloping and /or stepped.

11.7 Installation and inspection

For many events the front-of-stage barrier is necessarily one of the last things to be put in place and may be happening as the crowds are beginning to gather outside for the event. It is therefore all the more important that there are adequate checks to ensure that barriers have been properly erected in accordance with the details and procedures.

Checks should be made to ensure that all connecting bolts are properly fitted and that any pinning is correctly installed. Rubber matting or other material to improve frictional resistance, where provided, should be checked to ensure that it is correctly located beneath the footplate in accordance with the manufacturer’s details and that barriers are located accurately in accordance with the agreed site plan. Where multiple barrier systems are being used this is particularly important because ‘penned’ areas could become overloaded if they have been erected to form a smaller area than that which was used to determine the planned capacity.

The front-of-stage barrier is the first line of defence for the audience and vital to allow pit stewards to carry out their duties. It is as likely to be tested up to design loadings as any structure on an event site and should be accorded a high level of attention to ensure that all details are correctly completed.

11.8 References

Readers are advised to check for updates given to references throughout this document.

- 11.1 Health and Safety Executive. *The event safety guide: guide to health, safety and welfare at music and similar events*. London: HSE, 1999 (HSG 195)
- 11.2 Department of National Heritage and Scottish Office. *Guide to safety at sports grounds*. 4th ed. London: The Stationery Office, 1997
- 11.3 *BS EN 1991-1-1: 2002 : Eurocode 1: Actions on Structures. General actions. Densities, self-weight, imposed loads for buildings*. London: BSI, 2002
- 11.4 Shaughnessy, J. ‘Audience and crowd control’. in: Thompson, G. *Focal guide to safety in live performance*. Oxford: Butterworth-Heinemann, 1993

SECTION 12

TENTS AND MARQUEES

This Section is intended particularly for designers, contractors and suppliers of tents and marquees

“Tents and marquees should be capable of withstanding all forces which they may reasonably be expected to encounter. Of these, wind is the most important from a design point of view.”

“The design of new large marquees should be carried out by a competent person and subject to an independent check by a chartered engineer of appropriate skill and experience.”

“Tent structures often rely on individual guy ropes and anchors for their stability. Particular attention should therefore be given to the strength and soundness of such guy ropes and anchors, including the anchorage in the ground.”

“Anchors are a critical aspect of marquee structures.”

“After erection and before use, a tent or marquee should be thoroughly inspected and signed off by the contractor.”

12 TENTS AND MARQUEES

12.1 Introduction

Tents and marquees (a marquee is defined as a large tent) are structures covered by a flexible material supported by mechanical means such as beams, columns, poles, arches, ropes and/or cables. They provide shelter and protection from the weather by enclosing space using a flexible material, usually canvas or PVC. They are used wherever temporary accommodation is needed, such as at public shows and exhibitions, corporate functions, concerts, wedding receptions, parties and sporting events.

There are two broad categories, unframed and framed.

Traditional unframed tents have centre poles, and extensive use is made of guying to stabilise the fabric covering. Modern unframed tents and marquees may use timber, steel or aluminium poles or, particularly for larger structures, steel truss ‘poles’, to provide the upwards thrust required to resist the guy tensioning (see Figures 40 and 41).



Figure 40 A small traditional pole marquee



Figure 41 Large traditional marquees

Framed tents may be supported by timber, steel or aluminium portal or truss structures and are typically rectangular on plan. The fabric covering is typically supported by the framework, which is independently stable (see Figures 42 and 43).

Framed canopies using modern tensile fabrics, erected, for example, over platforms, seating tiers, arenas or stages require specialist input. They are usually designed and erected by specialist contractors whose professional experience and expertise is an important factor in the audit of the design by local authorities and independent checkers.

There are about 750 marquee contractors in the UK, and most of their work involves short-term hire, often for one day only. Most of their work is carried out between April and October, with a peak in June and July.

The reputation of marquee contractors rests on the quality of service provided to their clients. The good public safety record of the UK industry is due to a considerable extent to the quality of erection and maintenance of their hire fleet at base and in the field.



Figure 42 A large framed tent



Figure 43 The interior of a large framed marquee

The Performance Textiles Association (PTA) formerly known as The Made Up Textiles Association (MUTA), incorporates a Marquee Section, which is the trade organisation representing marquee contractors. It operates a self-regulatory scheme which imposes on its members compliance with a Code of Practice^{12.1} which the Association enforces through an Inspectorate.

12.2 Design

12.2.1 General

Tents and marquees should be capable of withstanding all forces which they may reasonably be expected to encounter. Of these, wind is the most important from a design point of view (see Section 8).

The design of new large marquees should be carried out by a competent person and subject to an independent check by a chartered engineer of appropriate skill and experience. 'Large marquees' are defined as:

- Pole marquees of a single span greater than 12m (40ft), and
- Framed marquees of a span greater than 9m (30ft).

In certain circumstances where large areas are covered by joined valley guttered tents, their design may require justification.

For tents, marquees and fabric-covered roofs, the stability of the main structure, including any guy rope anchors, should generally be independent of the sheeting fabric. Local tearing of the fabric should not result in the overall collapse of the main structure. The tearing strength and the pattern of seams should be such as to avoid unacceptable propagation of tears across the fabric. Tent structures often rely on individual guy ropes and anchors for their stability. Particular attention should therefore be given to the strength and soundness of such guy ropes and anchors, including the anchorage in the ground.

The frames of structures in which the fabric behaves purely as cladding and does not provide any necessary strength or stiffness may be designed in a similar manner to those in any traditional framed structure. However, the flexibility of the structure may be such that the non-linear effects of large displacements may need to be taken into account in the analysis. This is particularly true of large unframed tents supported by a system of guys and poles. These structures also rely entirely on the pre-stress in the system (tension in the guys and compression in the poles) to provide overall

stability. This needs to be carefully modelled in the analysis. Pre-tensions in the guys should be defined in the design calculations. It is important that these values are achieved during erection, either by direct load measurement or by accurate length control, within certain specified tolerances.

The design of unusually shaped canopies or tensile fabric structures, in which the fabric contributes to the structural strength or stiffness, requires sophisticated computer analysis for form-finding, stress determination and cutting pattern derivation. Specialist professional advice should be sought.

Particular care is required in the design and detailing of the stressing devices, cable terminations, guy attachments, rigging and stretching screws which enable the system to be adjusted and correctly tensioned. The connections between the fabric and guys, cables or poles need special attention. All details should avoid causing local stress concentrations in the fabric.

Rubbing and chaffing should be avoided by providing extra patches or protection to the fabric where cables or other elements are in contact with it.

Fabric which is not sufficiently tensioned or which is in loose contact with other elements may flap in the wind, creating an unpleasant noise and potential damage which can be avoided by careful structural design. Small panels of fabric may be stretched flat between robust structural elements, but greater stability and stiffness is achieved by providing fabric which has significant curvature in two directions.

Four critical elements may affect public safety in marquees and tents.

- Anchorage – see Section 12.2.2.
- Wind loading – see Section 8.3.
- Flame retardant capacity of materials – see Section 12.2.4.
- Quality of the finished structure in the field – see Section 12.5.

12.2.2 Anchors

Anchors are a critical aspect of marquee structures. The force that an anchor can withstand depends on:

- Type of ground.
- Moisture content.
- Inclination of anchor.
- Depth of anchor.
- Type of anchor.

The type of ground on which the marquee is erected has a large influence on the pull-out force that an anchorage can withstand.

Stiff to very stiff cohesive soils provide the best resistance to pull-out. For most soil types, steel pegs of an appropriate size are suitable.

Loose, non-cohesive soils such as sand provide the least resistance. Helical or screw anchors or kentledge of an appropriate weight may be required.

Concrete and similar bases will require specialist bolting systems of an appropriate capacity.

In the absence of full ground pull testing equipment, PTA guidance based on manually driven anchor stakes by a competent operator using maximum clean hits to affect minimum acceptable uplift should be used.

See Section 6 of this *Guide* for discussion of ground and site conditions, and Figure 7 for examples of types of ground anchor.

12.2.3 Wind loading

Wind loading of tents and marquees is discussed in Section 8.3.

12.2.4 Flame retardancy of fabric and materials

General

Modern fabric materials are generally flame retardant and fire resistant. However, special criteria may apply to tents or marquees, particularly where high occupancy levels are expected. The advice of the local authority fire officer should be sought.

All fabric should be inherently or durably flame-retardant and should be certified as conforming to Test 2 of BS 5438^{12.2}, Annex A of BS 7157^{12.3} or BS 7837^{12.4}.

Materials which are non-durably flame-retarded may be adversely affected by weathering, so fabric which has achieved the required level of flame retardancy by chemical treatment will need to be periodically retested. If the material is in constant use throughout the season (i.e. from April to October) such retesting should be carried out when the fabric is showing signs of obvious wear or ageing (after approximately five years). Thereafter, testing should be at two-yearly intervals. Such test results should be suitably certified.

Some marquees and large framed tents comprise a complete single unit (e.g. the marquees used for the Eisteddfod) and are used only occasionally (three or four times a year). Such marquees should have supporting documentation including test certificates which confirm their composition and standard flame retardancy, and diagrams or photographs of the structure. When they are used, a record should be

kept of each event and retesting will only need to be carried out when the fabric shows signs of wear or ageing.

All tent/marquee roof and wall panels should be labelled showing the following minimum information:

- Name of operator.
- Name of proofer/coater manufacturer.
- Year of first use.
- Flame retardancy standard applicable to fabric.

Textile floor coverings for marquees

Floor coverings used in tents and marquees may be reusable, such as coir or synthetic matting, or disposable, such as lightweight polypropylene carpets.

Some floor coverings may react in fire to produce large amounts of heat and smoke, although the rate of surface spread of flame may be relatively slow. The environment may also have a significant effect on the burning behaviour of materials, as wind can cause a fire to spread more rapidly. It can also blow smoke into escape routes and so adversely affect the means of escape. A similar situation may occur where a lack of adequate ventilation causes smoke to be concentrated in a particular area.

The most appropriate fire test for reusable floor coverings is BS 4790^{12.5}. Such flooring should comply with the low radius of effect of ignition in Table 1 of BS 5287^{12.6} (specifically for assessment and labelling of textile floor coverings tested to BS 4790). Disposable floor covering, which is through necessity lightweight, may not meet the performance specification in BS 5287. Nevertheless, such material may be accepted for a single use inside a marquee or tent provided that it falls within one of the classifications in BS 5287 and the flame spread time does not exceed 52mm/minute.

Materials for marquee lining drapes

All unattached lining drape materials should comply with Type B performance of BS 5867: Part 2^{12.7}.

Linings for marquees and large tents may be suspended using ropes constructed from man-made or natural fibres and may be laced together using the same materials. Linings should only be used if constructed from an appropriately and preferably inherently flame-retardant material. If materials requiring flame-retardancy re-treatment are used, e.g. cotton or wool, this process should be carried out according to manufacturers' instructions and a record kept accordingly.

12.3 Procurement and use of tents and marquees

Before an event, the responsibilities of the marquee contractor and the client should be clearly identified and agreed, along with an erection and dismantling schedule with adequate timescale for those operations to be carried out properly and safely. These will normally be set out in the contract and should preferably be standardised. Suppliers and contractors should make clients aware of their safety responsibilities.

12.3.1 Safety considerations – client

The following factors should be considered by the client when choosing a site and operating a tented structure.

Site plan

For larger events, it is recommended that an outline plan of all the structures on the site should be prepared by the client showing the position of all entrances and exits, generator equipment, vehicles, etc. It should be kept up-to-date on the site and be readily available for review. The plan should be agreed by the local authority, following consultation with the fire authority, having regard to occupancy, use, position and other factors relevant to safety. It should not be altered without reference to the local authority. The contractor should be furnished with the latest copies of such a plan.

The client should ensure that the needs and convenience of the disabled are taken into account when designing the event, and ensure that the contractor is advised of all such requirements at the outset.

Fire safety

Reference should be made to the fire authority and local authority for the appropriate provisions which apply. These will include, but not be limited to, issues about access routes, appropriate portable fire fighting equipment, access to hydrants and other water supplies. Other issues to consider include:

- Proximity of adjacent buildings, other temporary structures, vegetation and other fire risks in relation to the spread of fire.
- No dangerous, combustible or toxic gases or products such as aerosols, explosives or fireworks should be stored in a tented structure.
- Areas underneath stages and platforms should not be used for storage and rubbish should not be allowed to accumulate there. Such areas should be inspected daily to ensure conformity.

Loads

Nothing should be attached to or suspended from the tent without reference to and approval of the contractor.

Very few tented structures have snow-load capacity, and if snow is a possibility the structure should be heated in order to maintain a minimum temperature of 12°C to prevent build-up of snow on the roof.

Safety plan

The client should have access to a reliable local weather forecast and the means to contact the contractor for maintenance help should forecasted conditions dictate the need. The client should also consider the topography of the site and time of year and consult with the contractor as to the necessity of a maintenance team to be on site throughout the proceedings.

Erection

Nobody other than the contractor's staff or people under the contractor's supervision should be admitted to a tented structure or surrounding area until it is deemed structurally complete and safe.

Access and egress

Access and egress routes for the public, emergency vehicles and equipment should be kept free from obstruction at all times. When any person is in the tent, the exit doors should not be locked.

Where there are no doors, flap exits of quick release design should be provided. Where such arrangements are being used active management of the exit route by stewards should be considered.

Underground and overhead cables and other services

The client should notify the contractor of the presence and approximate position of underground services or overhead cables which may present hazards during the erection or use of the tent. If underground services or overhead cables cross sites where tents are to be erected, the client should first obtain advice from the service company concerned.

A telephone to call emergency services should be available. Emergency lighting should be provided for tents used during the hours of darkness to maintain an adequate level of lighting in the event of a power failure.

12.3.2 Safety considerations – contractor *Access and egress*

Tents intended to hold more than 50 people should have at least two suitable exits. Exits should be distributed evenly around the tent to provide genuine alternative routes from all parts of the tent. The maximum distance of travel from any part of a tent to a final exit should not normally be more than 24m. If the distance of travel includes a ramp or stairway, an additional 0.25m should be added to the actual distance of travel for every 1m of the ramp or stairway.

Entrance and exit ramps for the general public should not have a gradient of more than 1:12 and should be surfaced with a suitable non-slip material.

All doors on an exit route should open outwards and, where exit doors have to be secured against intruders, they should be fitted with panic bolts or latches to comply with BS EN 1125^{12.8}. Where there are no doors, flap exits of quick release design should be provided.

Emergency exit doors and flap exits should all be provided with exit signs conforming with the Health and Safety (Safety Signs and Signals) Regulations 1996^{12.9}. Responsibility for providing exit signs is a matter for agreement between contractor and client.

Stakes and ropes

Stakes and ropes near exits and walkways should be clearly marked or fenced-off to prevent members of the public from walking into or tripping over them.

Wind loading

The contractor should advise the client of the maximum in-service wind loadings expressed in mph and m/s for the tent(s) to enable a safety management plan to be activated accordingly.

Services

The contractor, notwithstanding the responsibility of the client, should establish the lines of any underground services and take all necessary measures to avoid them when anchorages or similar, are being driven into the ground.

Electrical installations should be installed, tested and maintained in accordance with the provisions of normative standards or national guidelines such as the IEE Wiring Regulations^{12.10}. Work on electrical installations and appliances should only be carried out by competent persons.

All means of heating other than electrical heating should be placed externally and ducted in by means of

flame-retardant hosing. Exceptions to this rule may be permitted by reference to the local authority.

Marquee contractors should have access to a reliable local weather forecasting service to determine the level of maintenance necessary during an event. Such services are available from the Meteorological Service, and also through PTA (see Appendix).

Marquee contractors should provide an out-of-office emergency telephone number and response service.

12.4 Erection, inspection and dismantling of tents and marquees

12.4.1 Erection

Tents and marquees should be erected and dismantled by competent persons. The manufacturer or supplier should provide a method statement for erection and dismantling.

The covering fabric and all supporting poles, frames, guys, stakes, anchors, fastenings, etc. should be checked to confirm that they are in good condition on delivery to site. Torn or damaged items should not be used.

Stakes and pegs for holding down spreaders, soleplates and cable anchorages are vital to the safety of tents and marquees and should be given particular attention. Inspection should make sure that all specified stakes and pegs are driven to the required depth.

Temporary props or guys are sometimes required. Specialist lifting, jacking or rigging systems may need to be employed during the erection of larger unframed tents, marquees, canopies or tensile structures. Competent specialist contractors should be used for this purpose. In some cases it is advisable to arrange qualified and experienced engineering supervision from specialist firms.

12.4.2 Inspection

After erection and before use, a tent or marquee should be thoroughly inspected and signed off by the contractor. The inspection should be based on a checklist and should include the following points which are recommended in the PTA Code of Practice^{12.1}.

- Anchorages should be suitable for purpose and hold fast.
- Bracing wires should be in place and properly tensioned.
- All ropes, including wire ropes, should be sound.
- The fabric should be tensioned and not prone to ponding.

- Exposed ropes and stakes adjacent to entrances and exits should be marked or fenced-off.
- All locking pins and bolts should be in place and secure.
- Eaves connection joints should be securely locked home.
- The fabric should not have any significant damage.
- Flooring should be evenly laid, securely fixed, with no tripping points.
- Timber uprights and ridges should be free from splits caused by damage.
- Walls should be securely pegged and/or secured.
- Poled marquees should have a full complement of side uprights, anchor stakes, pulley blocks and guy ropes.
- The main uprights should be independently guyed.

Adverse weather

Tents and marquees should be additionally inspected and monitored in the advent of adverse weather, and in severe conditions may need to be signed off again prior to public entrance.

Factors to be borne in mind include:

- Heavy rain or flooding may loosen ground anchorages and cause ‘ponding’ on the fabric.
- In strong winds, guy ropes may need regular tightening and pegs may need to be checked for movement.
- All entrances and exits to tents and marquees must be closed and secure during adverse weather conditions.
- Guy ropes and other tensioning systems may slacken after wet weather as they dry.
- Rubbing and chaffing should be avoided.

12.4.3 Dismantling

Care should be taken not to damage or stress poles, ridges, portal frames or other critical components particularly during lowering, dismantling or handling. Fabrics should be put away dry, and carefully folded up in the correct way to permit unfolding for easy erection at the next site. Fabric should be stored in dry, vermin-proof conditions. Cables and guys should be carefully coiled without kinks or any sharp bends.

12.5 Verification

Design stability calculations should be available for all large marquees, clearly stating the rated maximum service gust wind speed in mph and m/s. This should

be certified by a chartered engineer of appropriate skill and experience.

The MUTA Code of Practice Certificate may be accepted as evidence of satisfactory supplier performance.

Those tents designed empirically and used successfully by generations of marquee contractors, i.e. traditional marquees of 12m span or less and frame-supported tents of 9m span or less, can continue to be used without the necessity to produce stability calculations.

Verification of materials and of the competence of contractors and suppliers may be provided by various routes. These are discussed briefly below.

Under the self-regulatory scheme operated by PTA, member companies follow a Code of Practice which emphasises public safety, and permits only the use of fabric and materials which are approved by MUTA, with emphasis on flame-retardancy qualities.

Under this scheme, members are subject to both site and base inspection. A database of approved fabric suppliers is maintained, and members are obliged to record all fabrics used. Members are issued with a certificate of compliance and it is recommended that this may be accepted as evidence of the satisfactory performance of the marquee contractor. Further information is given in the PTA Code of Practice^{12.1}.

Where fabric for tentage is not endorsed by MUTAmarq, or an equivalent scheme, contractors should arrange for appropriate flame-retardancy certificates to be obtained from a NAMAS-registered testing house.

Any levelling platform or birdcage scaffold (scaffold grid) supplied by or through a marquee contractor should comply with BS EN 12811-1:2003^{12.11} and BS 5975: 1996^{12.12}. Loads should be as defined in BS 6399^{12.13, 12.14} or other documents as agreed by the client.

A self-check sign-off form should be available which is signed and dated by the site supervisor. Supervisors should have at least two years’ field experience. Competence of supervisors can be further evidenced by appropriate vocational qualifications.

A Level 3 National Vocational Qualification for senior staff involved in the erection, dismantling and signing-off of tented structures has been established by PTA along with an accreditation card scheme for site workers in the industry.

12.6 References

Readers are advised to check for updates given to references throughout this document.

- 12.1 Made-Up Textiles Association. *A code of practice for marquee hiring contractors and code of public safety: use and operation of marquees*. Tamworth: MUTA, 2001
- 12.2 *BS 5438: 1989: Methods for flammability of textile fabrics when subjected to a small igniting flame applied to the face of vertically oriented specimens*. London: BSI, 1989
- 12.3 *BS 7157: 1989: Method of test for the ignitability of fabrics used in the construction of large tented structures*. London: BSI, 1989
- 12.4 *BS 7837: 1996: Specification for flammability performance for textiles used in the construction of marquees and similar structures*. London: BSI, 1996
- 12.5 *BS 4790: 1987: Method of determination of the effects of a small cause of ignition on textile floor coverings (hot metal nut method)*. London: BSI, 1987
- 12.6 *BS 5287: 1988: Specification for assessment and labelling of textile floor coverings tested to BS 4790*. London: BSI, 1988
- 12.7 *BS 5867-2: 1980: Specification for fabrics, for curtains and drapes. Flammability requirements*. London: BSI, 1980
- 12.8 *BS EN 1125: 1997: Building hardware. Panic exit devices operated by a horizontal bar. Requirements and test methods*. London: BSI, 1997
- 12.9 *The Health and Safety (Safety Signs and Signals) Regulations 1996*. London: The Stationery Office, 1996 (SI 1996/341)
- 12.10 *BS 7671: 2001: Requirements for electrical installations. IEE Wiring Regulations*. London: BSI, 2001
- 12.11 *BS EN 12811-1: 2003: Temporary Works Equipment, Scaffolds, Performance Regulations and General Design*. London: BSI, 2004
- 12.12 *BS 5975: 1996: Code of practice for falsework*. London: BSI, 1996
- 12.13 *BS 6399-1: 1996: Loading for buildings. Code of practice for dead and imposed loads*. London: BSI, 1996
- 12.14 *BS 6399-2: 1997: Loading for buildings. Code of practice for wind loads*. London: BSI, 1997

SECTION 13
ANCILLARY AND SPECIAL STRUCTURES

This Section is intended particularly for designers, contractors and suppliers of ancillary and special structures

“Some of these structures differ from other structures discussed in this *Guide* in that during an event they are located in the middle of a venue and are surrounded by the audience.”

“As with other temporary structures, an independent design check should be carried out by a chartered engineer of appropriate experience.”

“It is paramount that the design of the structure is appropriate for the situation and that the structure is built strictly in accordance with the design.”

13 ANCILLARY AND SPECIAL STRUCTURES

13.1 Introduction

As well as grandstands, stages and tents, a wide variety of other temporary demountable structures are built at public sporting and entertainment events for many purposes, both indoors and outdoor. These structures include those to support loudspeakers and sound mixing equipment, video screens, camera platforms, display materials, score boards, lighting equipment, and the like. Because of the requirement for rapid erection and dismantling for touring concerts and events, they are often constructed of system scaffold or proprietary truss and tower systems. Examples of special structures are illustrated in Figures 44 to 48.

Some of these structures differ from other structures discussed in this *Guide* in that during an event they are located in the middle of a venue and are surrounded by the audience.



Figure 44 A scaffold tower



Figure 45 Video screen support structure

13.2 Design

13.2.1 General considerations

Structures forming masts, towers or subsidiary structures may be of proprietary systems or built from individual components such as scaffold tubes and fittings. The design may be by:

- Guidance and recommendations from the manufacturers of proprietary systems when these are based on proper research and design.
- Standard details prepared by a designer for a standard range of configurations.
- Standard details included in national Codes of Practice on design or the cumulative experience of industry over many years.

Notwithstanding the above, all structures shall be fully designed by a competent person.

As with other temporary structures, an independent design check should be carried out by a chartered engineer of appropriate experience.

However the design is carried out, it is paramount that the design of the structure is appropriate for the situation and that the structure is built strictly in accordance with the design.

When constructed and handed over, structures should be inspected on a regular basis by a competent person to identify faults and potential faults. Measures should also be taken to prevent trespassers from climbing or interfering with the completed structures.

These types of structure have certain common essential features which strongly influence their safety and integrity and these are discussed below.

13.2.2 Verticality

Unless specifically designed otherwise, all structures and their vertical supporting members should be as plumb as possible. The maximum out-of-plumb tolerance should be defined in the design calculations or operating manual.

13.2.3 Stability

The structures are normally quite slender and often need effective lateral support. They should be capable of resisting all overturning forces by a suitable margin (see Section 8.1.2). For example, the restoring moment shall be 1.5 times greater than the overturning moment when both moments are calculated using working unfactored loads.

The stability of each structure should be checked by calculation.

Stability can be provided by several methods:

- Having a suitable base area.
 - Having outriggers or stabilisers to form a suitable base area.
 - Using guy ropes.
 - Using kentledge.
 - Anchoring into the ground.
- or any combination of these.

13.2.4 Overloading

The loads applied to a structure should not exceed those considered in the design. Ancillary items such as loudspeakers, signs, banners, flags or cladding, when fixed to the structure, can attract significant wind loads. As noted elsewhere, all hanging items must have at least two independent fixings each capable of supporting the weight of the item.

Consideration shall be given as to how fabric elements are attached to the structure. For example, if a fabric sheet or wall is attached to the structure, then considerable vertical components of load can be induced on the structure. These vertical components can often be significantly more than the horizontal component.

Special care should be exercised when considering suspended loads. The calculations shall account for the transfer of load from the wind-loaded elements to the structure. For example, a rigid video screen suspended from its top edge (and not restrained from swaying) will transfer the wind load to the structure at the suspension point – not at its centre of area, thus having an increased load effect on both the structure and overturning when compared to a screen fixed into a structure in such a way that it can't sway. However, reference shall be made to the guidelines

from the manufacturer of the suspended equipment for hanging that equipment. It should be noted that the bending stresses induced by the wind are significantly different if the equipment is top hung only or is also restrained from swaying. It should also be noted that adding banners, cladding and the like can increase the wind loading significantly (see Section 8.2).

Risk assessment should recognise the possibility that structures may be climbed by members of the crowd, that other equipment may be tied to or placed against them, and that unplanned impact may occur. These may cause significant overloading.

It is important that the loads acting on the structures are controlled to ensure they are within the limits set by the design and that they are not placed so as to cause eccentric forces outside the design parameters.

Loads from lighting, public address equipment, etc. should be tabulated for each event and checked against the loads included by the original designer of the structure. This information should be made available to anyone who needs to know about such matters.

Where public address towers, mixing desks or other structures are located within the audience areas, consideration should be given to the effect of horizontal loading that may be exerted by spectators. Alternatively, the structures should be surrounded by a barrier adequate to resist the horizontal loading that may be exerted by spectators on the structure (see Section 11). If they are protected in this way by barriers, there is no need to consider these forces on the structure.

Where barriers are attached to the structure, the resultant worst-case combination of forces should be considered in the design process.

Many of these types of structure are made up from quite slender components. It is therefore important that the effective length of any of these carrying compressive loads is limited, this limitation being dependent on both the actual length and the degree of end fixity.

In the case of scaffold tubes and couplers, although the coupler can support quite large moments, it is generally assumed that this forms a pin joint, because of the uncertainty of the coupler fixing torque.

It is also important with these types of component that any horizontal loads are absorbed by bracing attached to the node points. This bracing should be arranged to direct the loads to the ground or to some rigid structure. As such bracing could be carrying compressive loads, its slenderness ratio should also be considered.

13.2.6 Scaffold

Ancillary and special structures constructed from tube and fitting scaffolding should be designed in accordance with BS EN 12811-1^{13.1} or BS 5975^{13.2} and the appropriate NASC guidance^{13.3}. Six aspects are important:

- The correct coupler should be used (see Section 9.5).
- All connection points at a node should be as close together as possible.
- The fixing torque on the coupler should be in accordance with the manufacturer's recommendations. Values of 40Nm to 70Nm are typical.
- Any tube carrying, or likely to carry, significant loads should penetrate the coupler by a minimum of 50mm and be fitted with a check coupler if required.
- Any joint made with a bolted coupler depends on the torque applied by an operative, and may therefore be subject to human error. Consequently all critical couplers and a random sample of non-critical couplers should be checked.
- Consideration should be given to using purpose designed 'System Scaffolds' where possible.



Figure 46 A look-out tower

13.2.7 Access

These ancillary and special structures will generally need access during erection, dismantling and often during use (see Section 7.1.2).

People should only climb heights appropriate to their training and abilities. They should be provided with adequate fall arrest equipment consistent with the task.

Access to parts of the structure above ground level shall be consistent with current work at height best practice and regulations.

All access shall be in accordance with the Work at Height Directive^{13.4} and the Work at Height Regulations 2005^{13.5}.

13.3 Masts and towers

The vertical elements of temporary demountable structures are generally known as masts or towers. This Section deals with vertical elements that do not form part of a larger structure.

Masts and towers are usually made from prefabricated proprietary or patent truss sections. When used free-standing to support equipment such as lights or loudspeakers they are usually restrained laterally by guy wires or attached to a weighted base. The guying is external to the footprint of the mast.



Figure 47 A tower supporting loudspeakers

Towers are typically built with patent system or traditional scaffolding or using prefabricated proprietary or patent truss sections with internal guying. They are frequently fitted with high-level platforms for workers and equipment. Rakers, outriggers and stabilisers can be used for stability, but the effective length of these needs to be controlled by the use of suitable bracing. Kentledge and guys may be employed outside the base area to ensure stability. Consideration shall be given to the coefficient of friction between the kentledge and the ground. This is site specific.

If prefabricated mobile access towers are used, then reference should be made to the manufacturer's instruction manual. Reference should also be made to BS EN 1004: 2004^{13.6} and BS EN 1298: 1996^{13.7}.

If kentledge is added to the bottom of a tower then this should be done carefully and attached to the tower in such a way as not to impose forces on elements of the tower or mast which could cause these elements to be overstressed. Towers and masts act in bending to resist the horizontal sway and wind forces.

Towers are sometimes used to support lighting, microwave equipment and aerials. People using or inspecting these structures should be alerted to the

potential dangers associated with these and any other 'live' equipment.

Barriers should be placed around guy lines when these are provided on masts. Adequate stewarding should also be provided to ensure that the guy lines are not tampered with.

With standard tower and mast units, manufacturers' instructions should be followed at all times. Only equipment designed for the purpose should be used as towers and masts.

In particular, equipment designed for indoor use, including proprietary load placement devices, should not be used outdoors.

Load placement devices should not be used as load-supporting devices.

If guy wires are used to provide lateral stability, then account shall be made of the vertical component of the force in the guy wire that acts on the tower or mast.

13.4 Catenary wire ropes

Equipment on event sites often requires electrical cables to be routed between locations. Generally this is best accomplished in underground ducts, by surface protection such as heavy rubber mats, or by



Figure 48 3-storey hospitality units

proprietary systems creating safe conduits within vehicle-proof ramps. Occasionally the only option is to take cables overhead. Any electrical cable should be supported from a tensioned steel wire rope (a catenary) in such a manner that no tensile force is applied to the cable.

This technique is sometimes considered to take audio cables from the stage to the control position in the middle of the audience (the front-of-house or mixer tower). Great care should be exercised as the tensile forces generated may be considerable, depending on the length and weight of the cable and the amount of 'sag' permitted.

On no account shall catenary wire ropes be used to support loads, especially above the public, unless calculations have been carried out by a competent person, taking into account the grade of wire required and the effects on the support structures. Specification of the type of steel catenary wire and details of the anchorages shall be included in the calculations.

13.5 Hospitality units

Special consideration shall be given to the design of hospitality units, with particular regard to the mobile nature of spectators and the related dynamic effects on the temporary structure (Figure 48).

An allowance should be made in the design of hospitality units for the possibility of dynamic effects and a notional horizontal load should be allowed for in the design in recognition of dynamic effects as shown in Table 12. This notional load does not allow for geometrical imperfections, such as lack of verticality.

13.6 References

Readers are advised to check for updates given to references throughout this document.

- 13.1 *BS EN 12811-1: 2003: Temporary works equipment. Scaffolds. Performance requirement and general design.* London: BSI, 2004
- 13.2 *BS 5975: 1996: Code of practice for falsework.* London: BSI, 1996
- 13.3 National Access and Scaffolding Confederation. *Technical guidance notes.* [various]
- 13.4 *Directive 2001/45/EC of the European Parliament and of the Council (OJ No L195, 19.7.02, p.46) amending Council Directive 89/655/EEC concerning the minimum safety and health requirements for the use of work equipment by workers at work (second individual Directive within the meaning of Article 16(1) of Directive 89/391/EEC)*
- 13.5 *The Work at Height Regulations 2005.* London: The Stationery Office, 2005 (SI 2005/735)
- 13.6 *BS EN 1004: 2004: Mobile access and working towers made of prefabricated elements. Materials, dimensions, design loads, safety and performance requirements.* London: BSI, 2005
- 13.7 *BS EN 1298: 1996: Mobile access and working towers. Rules and guidelines for the preparation of an instruction manual.* London: BSI, 1996

APPENDIX
SOURCES OF FURTHER INFORMATION

BRE Ltd

Garston, Watford WD25 9XX
Tel: +44 (0) 1923 664 000
Fax: +44 (0) 1923 664 010
Web: www.bre.co.uk

Chief and Assistant Chief Fire Officers' Association

10-11 Pebble Close, Amington,
Tamworth, Staffordshire B77 4RD
Tel: +44 (0) 1827 302 300
Fax: +44 (0) 1827 302 399
Web: www.cfoa.org.uk

Communities and Local Government

Eland House, Bressenden Place
London SW1E 5DU
Tel: 020 7944 4400
Fax: 020 7944 9645
Web: www.communities.gov.uk

Concert Promoters Association

6 St Marks Road, Henley on Thames,
Oxfordshire RG9 1LJ
Tel: +44 (0) 1491 575 060
Fax: +44 (0) 1491 414 082

Core Cities Group

Safety of Sportsgrounds
and Public Events Working Group
Manchester Building Control
PO Box 488, Town Hall
Manchester M60 2JT
Tel: 0161 234 4490
Fax: 0161 234 4551
Textphone: 0161 234 4330

Department of Culture, Music and Sport

2-4 Cockspur Street
London SW1Y 5DH
Tel: +44 (0) 20 7211 6200
Web: www.culture.gov.uk

Department of the Environment for Northern Ireland

10-18 Adelaide Street, Belfast BT2 8GB
Tel: +44 (0) 28 9054 0540
Fax: +44 (0) 28 9054 0106
Web: www.doeni.gov.uk

District Surveyors' Association

c/o LABC Services, 137 Lupus Street,
London SW1V 3HE
Tel: +44 (0) 20 7641 8737
Fax: +44 (0) 20 7641 8739
Web: www.labc.co.uk

Entertainment Services and Technology Association (ESTA)

875 Sixth Avenue, Suite 1005,
New York, NY 10001, USA
Tel: +44 1 212 244 1505
Fax: +44 1 212 244 1502
Web: www.esta.org

Football Licensing Authority

27 Harcourt House, 19 Cavendish Square,
London W1G 0PL
Tel: +44 (0) 20 7491 7191
Fax: +44 (0) 20 7491 1882
Web: www.flaweb.org.uk

Health and Safety Executive

Rose Court, Southwark Bridge,
London SE1 9HS
Tel: +44 (0) 20 7556 2100
Fax: +44 (0) 20 7556 2102
Infoline: 0845 345 0055
Web: www.hse.gov.uk

Home Office

2, Marsham Street,
London SW1P 4DF
Tel: +44 (0) 20 7035 4848
Fax: +44 (0) 20 7035 4745
Web: www.homeoffice.gov.uk

Production Services Association

PO Box 2709, Bath BA1 3YS
Tel: +44 (0) 1225 332 668
Fax: +44 (0) 1225 332 701
Web: www.psa.org.uk

Professional Lighting and Sound Association (PLASA)

38 St Leonards Road, Eastbourne,
East Sussex BN21 3UT
Tel: +44 (0) 1323 410 335
Fax: +44 (0) 1323 646 905
Web: www.plasa.org

Scottish Building Standards Agency

Denholm House
Almondvale Business Park
Livingston EH54 6GA
Tel: 01506 600 400
Fax: 01506 600 401
Email: info@sbsa.gov.uk
Web: www.sbsa.gov.uk

Scottish Executive Development Office

Victoria Quay
Edinburgh EH6 6QQ
Tel: +44 (0) 131 556 8400
Fax: +44 (0) 139 779 5001

Security Industry Authority

PO Box 9
Newcastle Upon Tyne NE82 6YX
Tel: +44(0) 8702 430 100
Fax: +44(0) 8702 430 125
Web: www.the-sia.org.uk

SPORTENGLAND

3rd Floor Victoria House, Bloomsbury Square,
London WC1B 4SE
Tel: 08458 508 508
Fax: +44 (0) 20 7383 5740
Web: www.sportengland.org

Sports Council for Northern Ireland

House of Sport, Upper Malone Road,
Belfast BT9 5LA
Tel: +44 (0) 28 9038 1222
Fax: +44 (0) 28 9068 2757
Web: www.sportni.net

Sports Council for Wales

Sophia Gardens,
Cardiff CF11 9SW
Tel: +44 (0) 29 2033 8200
Fax: +44 (0) 29 2030 0600
Web: www.sports-council-wales.co.uk

sportscotland

Caledonia House, South Gyle,
Edinburgh EH12 9DQ
Tel: +44 (0) 131 317 7200
Fax: +44 (0) 131 317 7202
Web: www.sportscotland.org.uk

Steel Construction Institute

Silwood Park, Ascot
Berkshire SL5 7QN
Tel: +44 (0) 1344 623 345
Fax: +44 (0) 1344 622 944
Web: www.steel-sci.org

The Events Services Association (TESA)

Association House, 18c Moor Street, Chepstow,
Monmouthshire NP16 5DB
Tel: +44 (0) 1291 628 103
Fax: +44 (0) 1291 630 402
Web: www.tesa.org.uk

The Institution of Structural Engineers

International HQ
11 Upper Belgrave Street,
London SW1X 8BH
Tel: +44 (0) 20 7235 4535
Fax: +44 (0) 20 7235 4294
Web: www.istructe.org

The Met Office [National]

Fitzroy Road, Exeter,
Devon EX1 3PB
Tel: +44 (0) 1392 885 680 or: 0870 900 0100
Fax: +44 (0) 1392 885 681 or: 0870 900 5050
Web: www.metoffice.gov.uk

The Performance Textiles Association

[formerly Made-Up Textiles Association]
42 Heath Street, Tamworth,
Staffordshire B79 7JH
Tel: +44 (0) 1827 52337
Fax: +44 (0) 1827 310 827
Web: www.performancetextiles.org.uk

uksport

40 Bernard Street London WC1N 1ST
Tel: +44 (0) 7211 5100
Fax: +44 (0) 7211 5246
Web: www.uksport.gov.uk

Temporary demountable structures

Guidance on procurement, design and use

Third edition

This document provides guidance on the procurement, design, erection and use of temporary demountable structures such as grandstands, marquees, stage structures and barriers. Towers and masts to support media facilities are also included. It is intended for event organisers, venue owners, local authorities, contractors and suppliers of demountable structures and for competent persons who are responsible for their design.

Demountable structures are used for a variety of functions at public and private events and may accommodate substantial numbers of people. The safety of users is of paramount importance, and guidance is offered on hazards and risks associated with these structures, and on achieving safe structures. New approaches to design of temporary structures to resist wind loads are presented, and extensive new information and guidance is given on statutory control, ground conditions, and inspection and erection.

Temporary demountable structures differ from conventional structures in several ways:

- They are often required at short notice so clients, contractors and local authority officers may have to make decisions quickly.
- They may need to withstand substantial horizontal and vertical loads from crowds, and from wind.
- The structural components are often lightweight, rapidly assembled, readily dismantled and reusable.

The approach to planning, design, erection and use thus needs to be one of flexibility and judgment.

This third edition of the *Guide* has been prepared by an expert group with representatives from industry, government and the Institutions of Structural and of Civil Engineers.

The Institution of Structural Engineers

International HQ, 11 Upper Belgrave Street, London SW1X 8BH, United Kingdom

T: +44 (0) 20 7235 4535

F: +44 (0) 20 7235 4294

E: mail@istructe.org

W: www.istructe.org

